

# 112 Series Valves

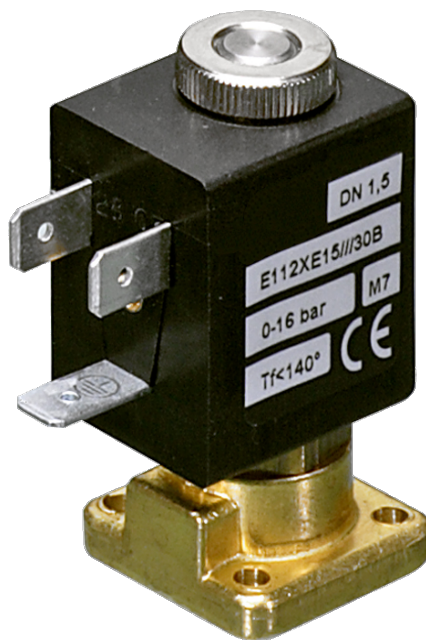

800.909.4988  
info@rankinusa.com

**RANKIN**   
COMPONENTS THAT AUTOMATE



| COILS<br>Code ②        | Alternating Current |     |          |     |          |     | Direct Current |     |          |     | Electrical<br>connection | Connectors              |
|------------------------|---------------------|-----|----------|-----|----------|-----|----------------|-----|----------|-----|--------------------------|-------------------------|
|                        | 24V                 |     | 120V     |     | 240V     |     | 12V            |     | 24V      |     |                          |                         |
| Series 3<br>Width 22mm | U35B<br>            | 30B | U35D<br> | 30D | U35F<br> | 30F | U350<br>       | 300 | U351<br> | 301 | DIN 46244                | PG9<br>code<br>10348000 |
| Series 4<br>Width 30mm | -                   | 40B | -        | 40D | -        | 40F | U450<br>       | 400 | U451<br> | 401 | DIN 43650A               | PG9<br>code<br>10349000 |

**DESCRIPTION**  
 Class F or H insulation  
 Voltage tolerance  $\pm 10\%$   
 Protection class:  
 IP65 with connector attached  
 IP00 without connector  
 Continuous service ED100%

**OPTIONS**  
 Cable attached  
 Special coil voltage  
 Special coil powers

### OVERALL DIMENSIONS

inches (mm)



Series 3 Weight 0.11lb (0.05Kg)

Series 4 Weight 0.22lb (0.1Kg)

**FOR COIL SPECIFICATION SEE SECTION 6**

### SPARE PARTS LIST

1. Coil fixing nut
2. Coil
3. Plunger assembly assembly
4. Armature tube assembly
5. OR 2068
6. OR 2010

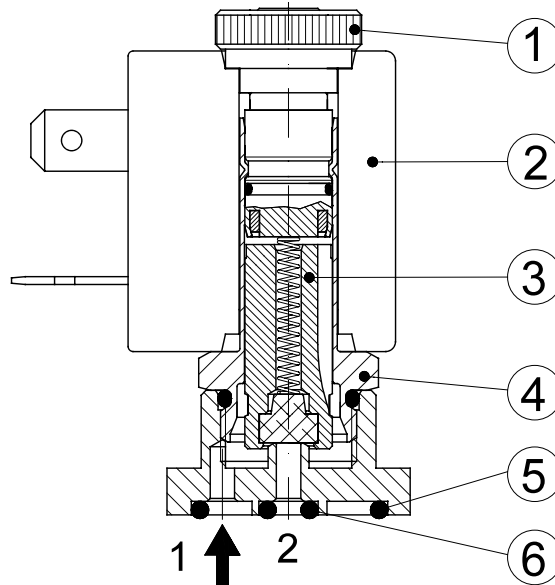

### OVERALL DIMENSIONS

inches (mm)

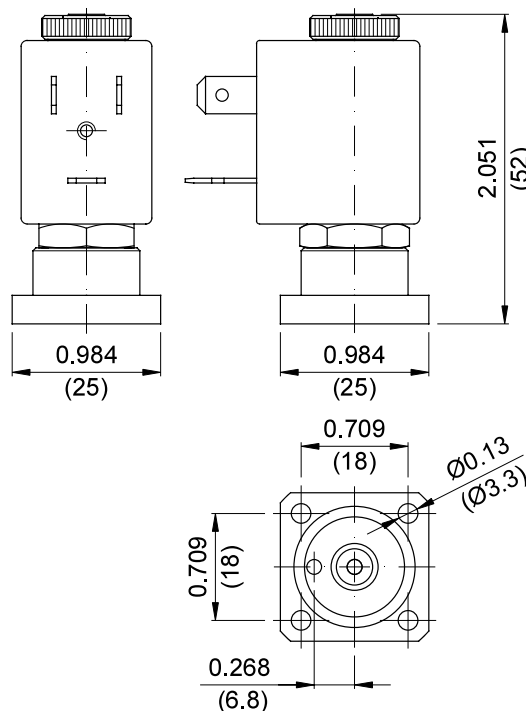

Weight with coil series 3=0.26lb (0.12Kg)  
 Weight with coil series 4=0.37lb (0.17Kg)