

117 Series Valves

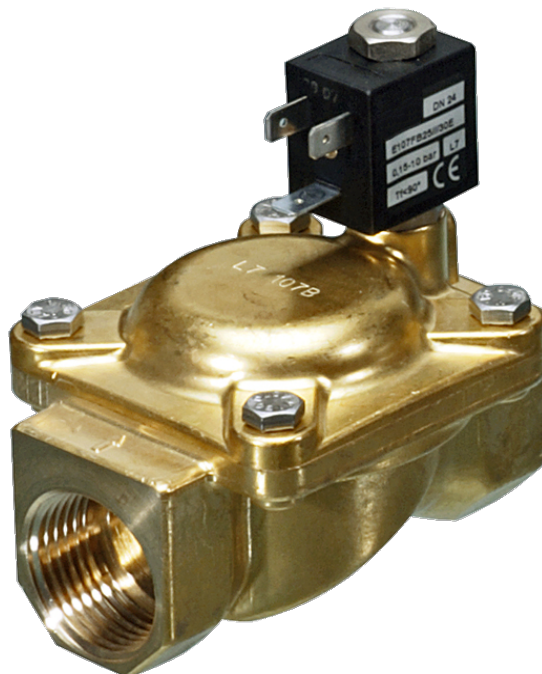

800.909.4988
info@rankinusa.com

RANKIN 
COMPONENTS THAT AUTOMATE

DESCRIPTION

Solenoid valve 2 way with servo-assisted diaphragm bi-stable.

The bi-stable function is achieved by the use of a polarized permanent magnet energizing the coil with a DC current for at least 15ms in the reverse direction of the previous impulse.



CONSTRUCTION

Body and cover	Brass
Armature tube	AISI 303
Plunger and core	AISI 430FR
Magnet	NeFeB
Springs	AISI 302
Seal material	NBR - FPM - EPDM

FEATURES

- Minimum differential pressure 0.15bar
- Maximum allowable pressure PS 25bar^③
- Maximum fluid viscosity 25cSt (mm²/s)
- Ambient temperature: from -10°C to +80°C according to the coil
- Preferred mounting position with vertical coil above

OPTIONS: Special coil powers

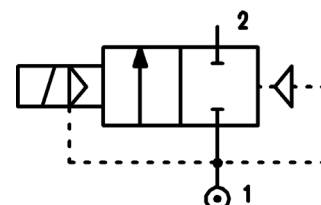

4

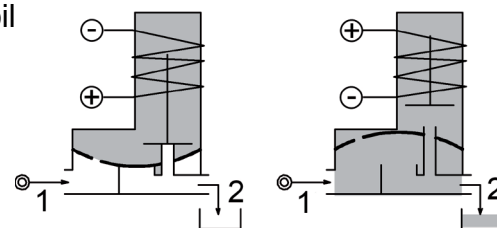

CODE ① ②	Connection G ISO 228	Orifice mm	Kv m ³ /h	Differential pressure bar		Nominal power DC Watt	Coil		Seal ①	Temp. range °C
				Min	Max		Series	Width		
D117B...10///...	1/4"	10	1.5	0.15	8	2	3	22	NBR=B	-10 +90
					15	5				
D117C...10///...	3/8"	10	1.7	0.15	8	2				
					15	5				
D117C...12///...	3/8"	12	2.2	0.15	8	2				
					15	5				
D117D...12///...	1/2"	12	2.5	0.15	8	2				
					15	5				
D117E...18///...	3/4"	18	5.5	0.15	8	2				
					13	5				
D117F...25///...	1"	25	10.2	0.15	8	2				
					10	5				
D117G...30///...	1"1/4	30	15	0.15	8	2				
					10	5				

① Seal Example: D117DB12///301120 NBR seal
 ② Coil Coil 24V DC 2W

③ The maximum allowable pressure PS for steam 2,5bar (gauge pressure)

COILS ②	Direct Current															Electrical connection	Connectors
	3V			6V			9V			12V			24V				
	2W	5W	6.5W	2W	5W	6.5W	2W	5W	6.5W	2W	5W	6.5W	2W	5W	6.5W		
Series 2 Width 30	308120			305120	305150		307120	307150		300120	300150	300	301120	301150	301	DIN 46244	PG9 code 10348000

DESCRIPTION
 Class F insulation
 Voltage tolerance ± 10%
 Protection class
 IP65 with connector fitted
 IP00 without connector
 Continuous service ED100%

OPTIONS
 Class H insulation
 Cable attached
 Special coil voltage
 Special coil powers

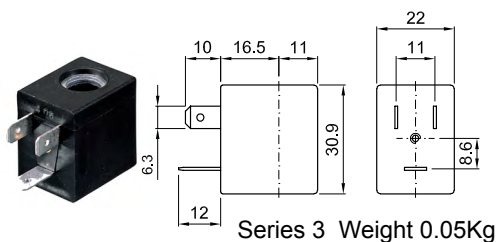

SPARE PARTS LIST

1. Coil fixing nut
2. Coil
3. Plunger
4. Armature tube with core
5. Diaphragm assembly

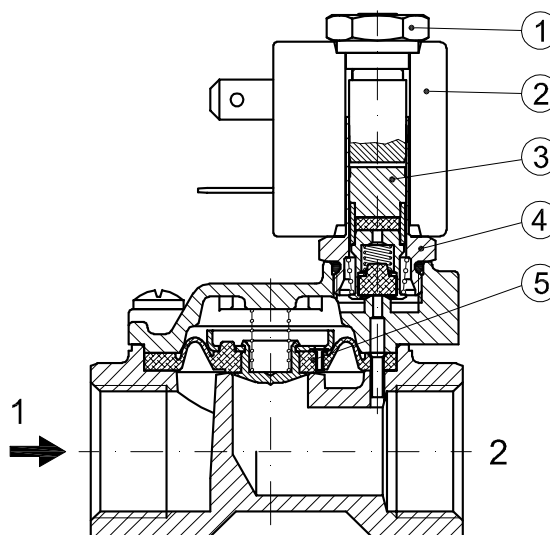

OVERALL DIMENSION

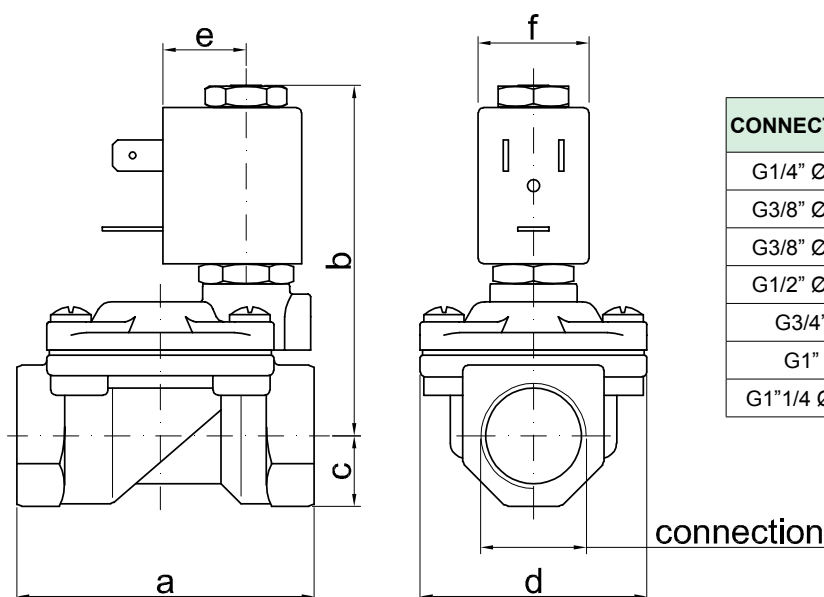

CONNECTION	a	b	c	d	e	f	weight Kg
G1/4" Ø10	49	65	11	32	16	22	0.23
G3/8" Ø10	49	65	11	32	16	22	0.24
G3/8" Ø12	59	70	14	45	16	22	0.42
G1/2" Ø12	59	70	14	45	16	22	0.39
G3/4"	79	76	18	55	16	22	0.65
G1"	96	85	20	72	16	22	1.05
G1"1/4 Ø30	119	92	25	85	16	22	1.70

DESCRIPTION

Solenoid valve 2 way with servo-assisted diaphragm bi-stable.
The bi-stable function is achieved by the use of a polarised permanent magnet energising the coil with a DC current for at least 15ms in the reverse direction of the preceding impulse.



CONSTRUCTION

Body and cover	Brass
Armature tube	AISI 303
Plunger and core	AISI 430FR
Magnet	NeFeB
Springs	AISI 302
Seal material	NBR - FPM - EPDM

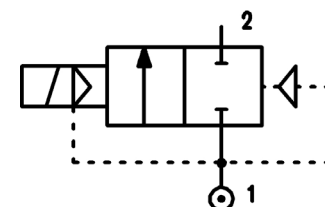

4

FEATURES

Minimum differential pressure 0.15÷3bar
Maximum allowable pressure PS 20bar^④
Maximum fluid viscosity 25cSt (mm²/s)
Ambient temperature: from -10°C to +80°C according to the coil
Preferred mounting position with vertical coil above

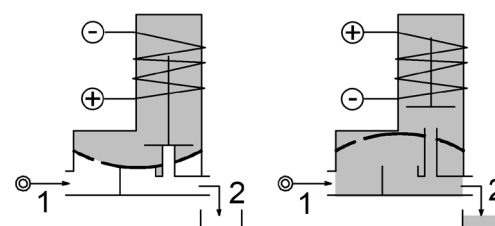

OPTIONS: Special coil powers

CODE ① ②	Connection G ISO 228	Orifice mm	Kv m ³ /h	Differential pressure bar		Nominal power DC Watt	Coil		Seal ①	Temp. range °C		
				Min	Max		Series	Width				
D117G...37///...	1"1/4	37	18	0.15	10	10	2	30	NBR=B	-10 +90		
D117H...37///...	1"1/2	37	21	0.15	10							
D117I...50///...	2"	50	36	0.15	10							
D117MB75///...	2"1/2	75	75	0.3	5				EPDM=E	-10 +120		
D117RB75///...	3"	75	84	0.3	5							
③D117RB75/W/...	2"1/2	75	75	3	10						FPM=V	-10 +120
③D117MB75/W/...	3"	75	84	3	10							

① Seal Example: D117IB50///201 NBR seal
② Coil Coil 24V DC
③ Reinforced diaphragm

④ The maximum allowable pressure PS for steam 2,5bar (gauge pressure)

G2"1/2 e G3" SOLENOID VALVES

For applications with fluids listed in chapter 3 / group 1 of the PED Directive 2014/68 / EU (potentially hazardous or explosive fluids / mixtures) consider a PS value reduced to 15 bar max.

COILS ②	Direct Current (V)			Electrical connection	Connectors
	12	24	48		
Series 2 Width 30	200	201	202	DIN 43650A	PG9 code 10349000

DESCRIPTION
 Class F insulation
 Voltage tolerance
 AC +15% -10%
 DC ± 10%
 Protection class
 IP65 with connector fitted
 IP00 without connector
 Continuous service ED100%

OPTIONS
 Class H insulation
 Cable attached
 Special coil voltage
 Special coil powers

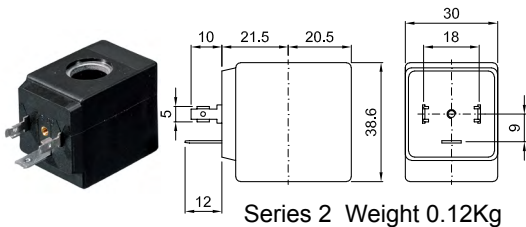

SPARE PARTS LIST

1. Coil fixing nut
2. Coil
3. Plunger
4. Armature tube with core
5. Diaphragm assembly
6. Speed control valve
7. Water hammering reducer
 $\varnothing 0.8$ - $\varnothing 1.2$ - $\varnothing 1.5$

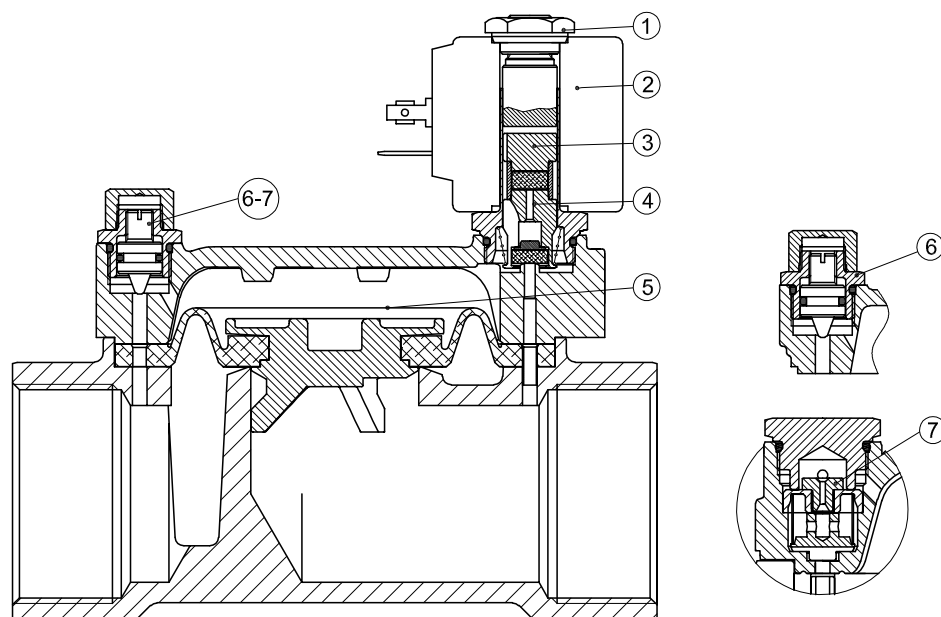

OVERALL DIMENSION

CONNECTION	a	b	c	d	e	f	weight Kg
G1"1/4	142	105	28	102	21	30	3.00
G1"1/2	142	105	28	102	21	30	2.85
G2"	158	115	35	119	21	30	4.30
G2"1/2	226	134	51	169	21	30	11.7
G3"	226	134	51	169	21	30	9.9