

168 Series NPT Thread



800.909.4988 // info@rankinusa.com // rankinusa.com

RANKIN 
COMPONENTS THAT AUTOMATE

DESCRIPTION

Solenoid valve 2 way normally closed with assisted-lift diaphragm

CONSTRUCTION

Body and cover	Brass
Armature tube	AISI 303
Plunger and core	AISI 430FR
Springs	AISI 302
Seal material	FPM
	NBR (on request)



FEATURES

Maximum fluid viscosity 25cSt (mm²/s)
 Ambient temperature: from +14°F to +176°F according to the coil
 Preferred mounting position with vertical coil above

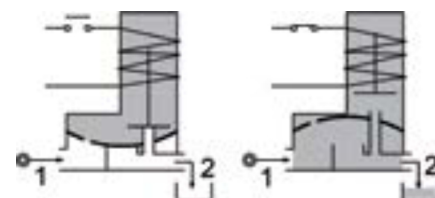
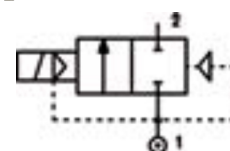

4



OPTIONS: ATEX Ex d coils
 Degreased for use with oxygen

CODE ① ②	Port Size NPT	Orifice mm		Flow Factor Cv (gpm)	Min (psi)	Operating Pressure Differential (M.O.P.D.) ③				Nominal power	Coil		Seal ①	Temp. range (°F)
		(in)	(mm)			Max		Series	Width (mm)					
						AC (psi)	DC (bar)							
E168CNV11///...	3/8"	0.43	11	1.38	0	203	14	72.5	5	10W	2	30	FPM=V	+14 +284
						-	-	203	14	27W	5	36		
E168DNV16///...	1/2"	0.63	16	2.77	0	203	14	36	2.5	10W	2	30		
						-	-	203	14	27W	5	36		
E168ENV16///...	3/4"	0.63	16	2.77	0	203	14	36	2.5	10W	2	30		
						-	-	203	14	27W	5	36		
E168ENV20/H/...	3/4"	0.79	20	8.32	0	232	16	72.5	5	10W	2	30		
						-	-	232	16	27W	5	36		
E168FNV25///...	1"	1	25	8.32	0	116	8	-	-	10W	2	30		
						203	14	22	1.5	14W	5	36		
						-	-	87	6	27W	5	36		
E168FNV25/H/...	1"	1	25	9.71	0	232	16	72.5	5	10W	2	30		
						-	-	232	16	14W	5	36		
E168GNV35///...	1"1/4	1.38	35	18.7	0	232	16	-	-	10W	2	30		
						-	-	87	6	14W	5	36		
						-	-	232	16	27W	5	36		
E168HNV40///...	1"1/2	1.57	40	19.4	0	232	16	-	-	10W	2	30		
						-	-	87	6	14W	5	36		
						-	-	232	16	27W	5	36		

① Seal

② Coil

③ Safe Working Pressure: 232 psi. Is the line or system pressure to which the valve may be subjected without being damaged.
 The maximum allowable pressure PS for steam is 36 psi.

COILS ②	Alternating Current 50/60Hz (60Hz for UL coils) (V)							Direct Current (V)		Electrical connection	Connectors
	12	24	48	110	220 230	240	380	12	24		
Series 2  Width 30-10W	-	U25B	-	U25D	U25E	U25F	-	U250	U251	DIN 43650A	PG9 code 10349000 or PG11 code 10349001
Series 5  Width 36-14W	-	U55B	-	U55D	-	U55F	-	U550	U551		
Series 5 Width 36-27W	52A	52B	52C	52D	52E	52F	52G	520	521		

DESCRIPTION
 Class H Insulation
 Voltage tolerance
 AC +15% -10%
 DC ± 10%
 Protection class
 IP65 with connector fitted
 IP00 without connector

OPTIONS
 Cable attached
 Special coil voltage
 Special coil powers

OVERALL DIMENSIONS

inches (mm)

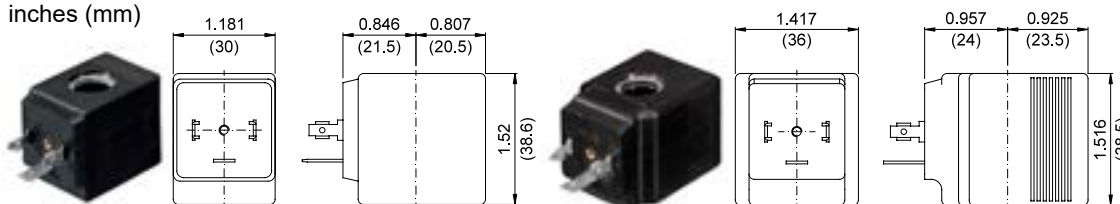

Series 2 Weight 0.26lb (0.12Kg)

Series 5 Weight 0.44lb (0.20Kg)

(for coil details see section 6)

SPARE PARTS LIST

1. Coil
2. Armature tube
3. Armature tube OR
4. Diaphragm assembly+plunger

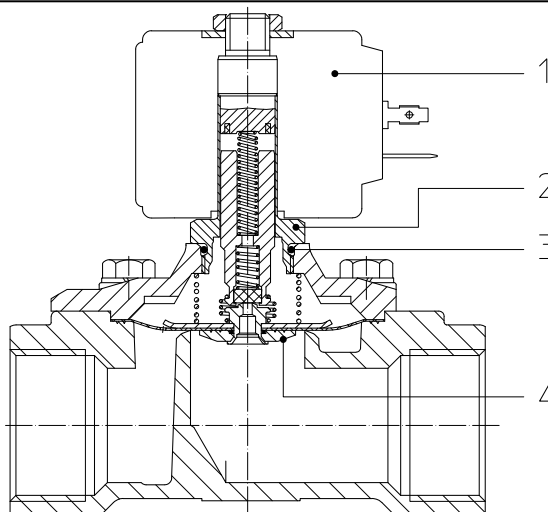

OVERALL DIMENSION

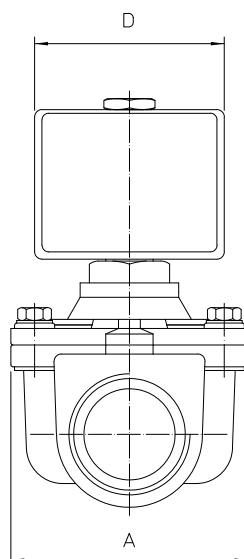
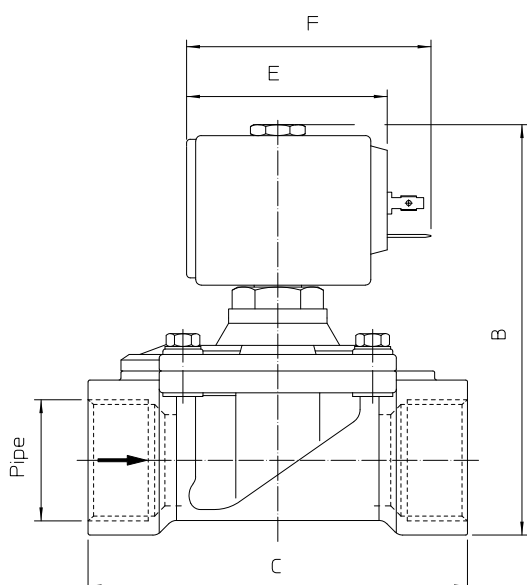

PIPE NPT	A		B		C	
	in	mm	in	mm	in	mm
3/8"	2	50	3,5	89	2,2	56
1/2"	2	50	4	100	2,76	70
3/4"	2	50	4	100	2,76	70
3/4" /H	2,6	65	4,1	103	4,1	104
1"	2,6	65	4,4	112	4,1	104
1" /H	2,6	65	4,3	110	4,1	104
1"1/4	3,7	94	5,1	130	5	128
1"1/2	3,7	94	5,1	130	5	128

COIL TYPE	D		E		F	
	in	mm	in	mm	in	mm
Series 2 30mm	1,2	30	1,65	42	2,1	54
Series 5 36mm	1,4	36	1,9	48	2,4	60

168 Series BSP Thread



800.909.4988 // info@rankinusa.com // rankinusa.com

RANKIN 
COMPONENTS THAT AUTOMATE

Technical information are provided for informative purpose only and can be subject to change without prior notice

DESCRIPTION

Solenoid valve 2 way normally closed with assisted-lift diaphragm

CONSTRUCTION

Body and cover	Brass
Armature tube	AISI 303
Plunger and core	AISI 430FR
Springs	AISI 302
Seal material	FPM
	NBR (on request)



FEATURES



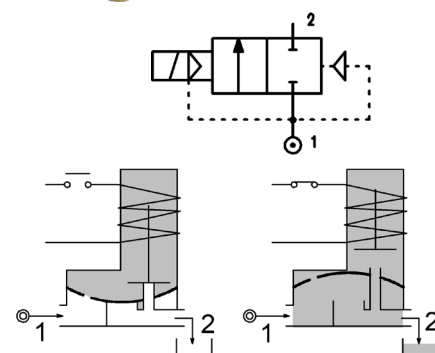

- Maximum allowable pressure PS 16bar^③
- Maximum fluid viscosity 25cSt (mm²/s)
- Ambient temperature: from -10°C to +80°C according to the coil
- Preferred mounting position with vertical coil above

- OPTIONS:**
- UL[®] US certified coils
 - NPT connections
 - ATEX Ex d coils
 - Degreased for use with oxygen



CODE ① ②	Connection G ISO 228	Orifice mm Ø	Kv m ³ /h	Differential pressure bar		Nominal power	Coil		Seal ①	Temp. range °C	
				Min	Max		Series	Width			
E168CV11///...	3/8"	11	1.2	0	14	5	10W	2	30	FPM=V	-10 +140
					-	14	27W	5	36		
E168DV16///...	1/2"	16	2.4	0	14	2.5	10W	2	30		
					-	14	27W	5	36		
E168EV16///...	3/4"	16	2.4	0	14	2.5	10W	2	30		
					-	14	27W	5	36		
E168EV20/H/...	3/4"	20	7.2	0	16	5	10W	2	30		
					-	16	27W	5	36		
E168FV25///...	1"	25	7.2	0	8	-	10W	2	30		
					14	1.5	14W	5	36		
					-	6	27W	5	36		
E168FV25/H/...	1"	25	8.4	0	16	5	10W	2	30		
					-	16	14W	5	36		
E168GV35///...	1"1/4	35	16.2	0	16	-	10W	2	30		
					-	6	14W	5	36		
					-	16	27W	5	36		
E168HV40///...	1"1/2	40	16.8	0	16	-	10W	2	30		
					-	6	14W	5	36		
					-	16	27W	5	36		

- ① Seal
- ② Coil
- ③ The maximum allowable pressure PS for steam 2,5bar (gauge pressure)

COILS ②	Alternating Current 50/60Hz (V)							Direct Current (V)		Electrical connection	Connectors
	12	24	48	110	220 230	240	380	12	24		
Series 2 Width 30-10W	20A	20B	20C	20D	20E	20F	20G	200	201	DIN 43650A	PG9 code 10349000 or PG11 code 10349001
Series 5 Width 36-14W	-	U55B c  US	-	U55D c  US	-	U55F c  US	-	U550 c  US	U551 c  US		
Series 5 Width 36-27W	52A	52B	52C	52D	52E	52F	52G	520	521		

DESCRIPTION
 Insulation class
 Series 2 =F Series 5=H
 Voltage tolerance
 AC +15% -10%
 DC ± 10%
 Protection class
 IP65 with connector fitted
 IP00 without connector

OPTIONS
 Class H insulation (series 2)
 Cable attached
 Special coil voltage
 Special coil powers
 c  US certified coils

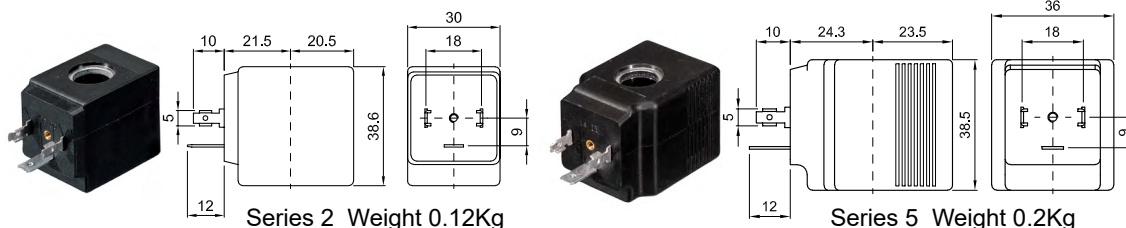

(for coil details see section 8)

SPARE PARTS LIST

1. Coil
2. Armature tube
3. Armature tube OR
4. Diaphragm assembly+plunger

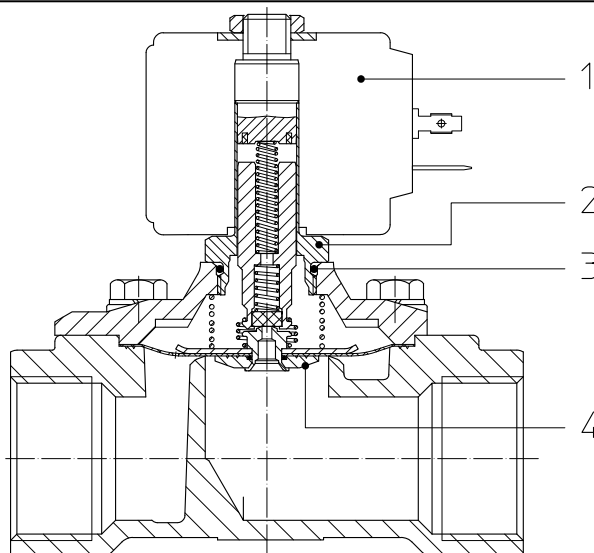

OVERALL DIMENSION

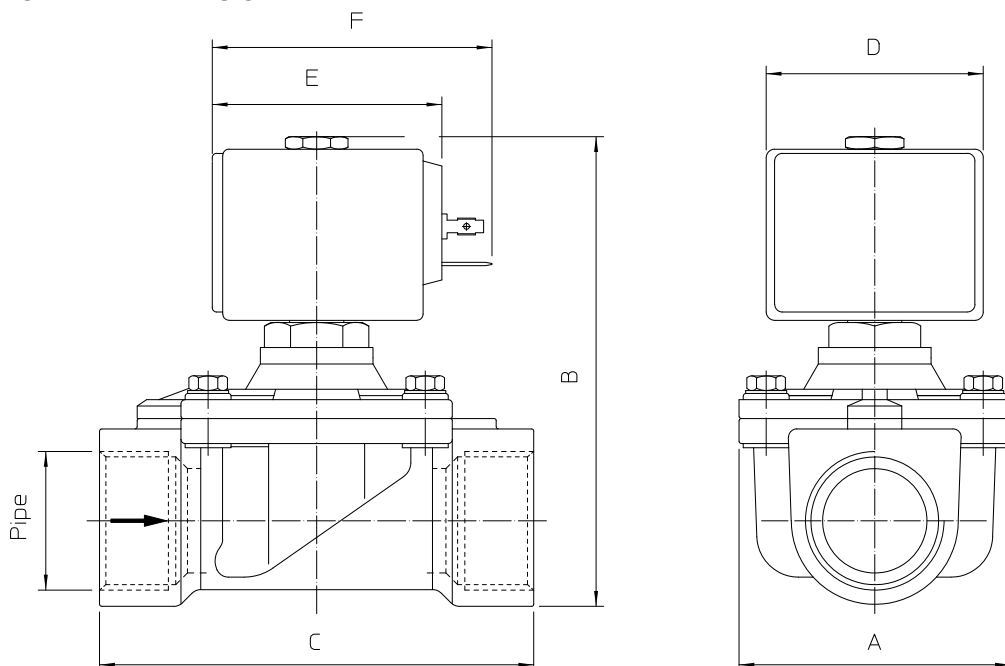

PIPE	A	B	C
G3/8"	50	89	56
G1/2"	50	100	70
G3/4"	50	100	70
G3/4" /H	65	103	104
G1"	65	112	104
G1" /H	65	110	104
G1"1/4	94	130	128
G1"1/2	94	130	128

COIL TYPE	D	E	F
Series 2 30mm	30	42	54
Series 5 36mm	36	48	60