

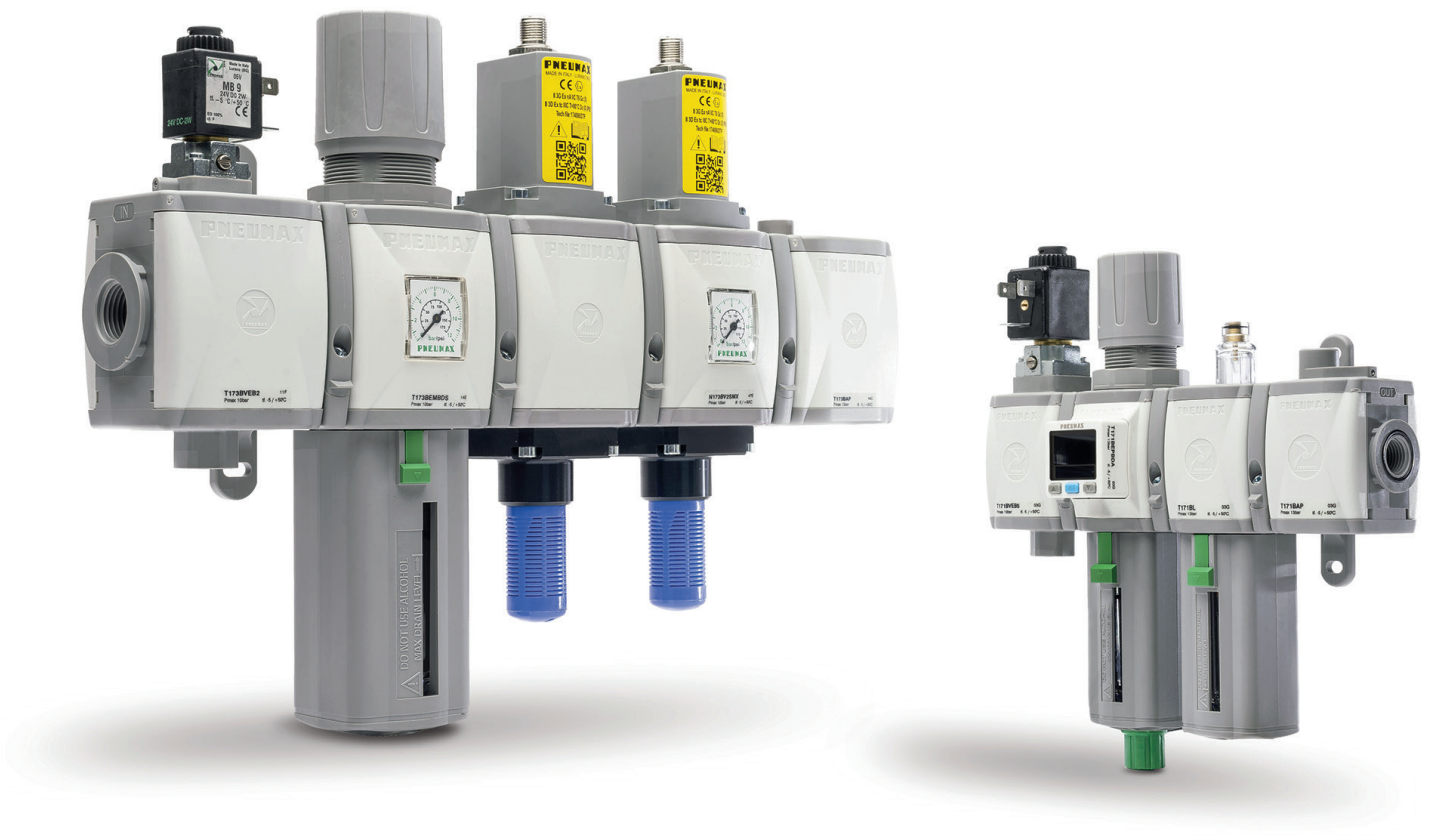

PNEUMAX



SERIES 1700 AIR TREATMENT



Air service units, series 1700

- Modular system
- Available for 4 sizes with connections from 1/8" to 1"
- ATEX certification (II 2GD o II 3GD) on request



2

AIR TREATMENT

Construction and working characteristics

1700 air treatment series includes a wide range of elements for individual use or modular assembling.

Available in 4 sizes e connections from 1/8" to 1".

The bowls are made in zinc alloy body with zinc alloy integrated connections, technopolymer with integrated metal connections for size 1 and aluminium with integrated aluminium connections for sizes 2, 3 and 4.

The bowls are in Nylon, with technopolymer protection for sizes 1, 2, 3 (also available for size 1 without protection). The bowls are in metal with condensation drain display for size 4.

Filters can be equipped with manual or semiautomatic condensation drain; furthermore it's possible to install the automatic draining device inside the bowl.

Wall mounting by means of screws directly through the body and hidden by protective covers.

The pressure regulator handle is lockable in the desired position, the shut-off valves are lockable with a maximum of three pad-locks to prevent accidents or damages due to unauthorized operation.

The lubricator oil flow is adjustable with proper handle and it is visibly checked through the sight dome.

The progressive start-up valve, pneumatically or electropneumatically controlled, allows air supply to the circuit progressively and with adjustable time. The accessories like panel mounted brackets, pressure gauges with different scales and diameters and the air intake blocks are completing the range. They are assembled between the elements to get filtered or filtered non-lubricated air in the system.

Instruction for installation and operation

Pay attention to install a group or a single component with air flow direction according to the arrows and to the following sequence: filter, pressure regulator, lubricator and with bowls downwards. The group can be fixed to the wall by removing the covers, which can be installed again after fixing for covering the screws. Do not exceed the recommended torque while assembling the connectors.

Do not exceed the recommended air pressure and temperature limits. The moisture should not exceed the level marked on the bowl and it can be drawn off and carried by a flexible tube of Ø 6/4 directly connected to the discharge valve handle.

The pressure should be set from minimum to maximum, rotating the adjusting handle clockwise.

As lubricant, we suggest to use oil class FD22 or HG32. Verify that the lubricator is not fed with a flow lower than the minimum operational.

To set the oil flow rotate the proper adjusting handle in order to get one drop of oil every 300-600 liters of air.

The oil flow will be kept automatically and proportionally to the air flow. The oil can be refilled by mean of proper plug or directly into the bowl after having de-pressurized the system. Do not exceed the maximum level indicated on the bowl. For opening the shut-off valve push and rotate clockwise the operating handle. For closing it and consequently discharging the down stream line, rotate the handle counter-clockwise.

Maintenance

Clean the bowls with water and detergent. Do not use alcohol.

The filter element made with HPDE is reusable by blowing and cleaning it with proper detergent. For replacing or cleaning it, remove the bowl and unscrew the baffle spins.

Replace the pressure regulator diaphragm whenever the operation is not correct or there is a continuous air leaking through the relieving (over pressure discharge); reinstall the adjusting mechanism support, locking it with about 8 Nm torque. In case it is necessary to replace the lubricator transparent dome, tight it at 5 Nm torque maximum.



▶ **High sensitive air pressure regulators with high flow rate relieving**



- ▶ Accurate capacity to maintain set pressure
- ▶ Sensitivity combined with high relieving rates
- ▶ High flow rate with extremely low pressure drop
- ▶ Pressure adjusting lockable handle by simply pressing it downwards in the desired position
- ▶ Aluminium body
- ▶ Ring nut for panel mounting
- ▶ Construction with controlled refiel
- ▶ Atex certification (II 2GD) on request

2

AIR TREATMENT

Technical characteristics	Size	
	Size 1	Size 3
Body and connections type	Aluminium body, integrated aluminium connections	
IN / OUT connections	G1/4"	G1/2"
Assembly configuration	Stand alone Panel mounting With fixing bracket	Stand alone Panel mounting With fixing bracket
Assembly position	Indifferent	
Fluid	20µ filtered air and preferably non lubricated	
Air flow with inlet pressure 10 bar (NI/min)	5	
Pressure range (bar)	0,1 - 2 / 0,1 - 4 / 0,1 - 7 / 0,1 - 10	
Regulation	Manual push and lock with pressure Manual lockable with accessories	
Pressure measurement	G1/8" Pressure gauge connection port	
Max. fittings torque IN / OUT connections	G1/4" metal: 20	G1/2" metal: 30

Operational characteristics	Size	
	Size 1	Size 3
Maximum working pressure (bar)	10	
Minimum working pressure (bar)	0,5	
Working temperature (°C)	-5 ÷ +50	

Weights	Size	
	Size 1	Size 3
Aluminium body version (g)	380	970

Order codes

17 3S2B . 0010 . E . K

Size, body and connections

1S2B : Aluminium body, connections G1/4" (only for size 1)
3S2B : Aluminium body, connections G1/2" (only for size 3)

Pressure range

0002 : 0,1 - 2 bar
0004 : 0,1 - 4 bar
0007 : 0,1 - 7 bar
0010 : 0,1 - 10 bar

Type

: Standard
E : External pressure feedback

Options

: Standard
K : Lockable version
U : Lockable version with universal key

Example: 173S2B.0010.E.K

Size 3 high sensitive air pressure regulator with high flow rate relieving, aluminium body, G1/2" connections, 0,1 - 10 bar, external pressure feedback, lockable version

Dimensions

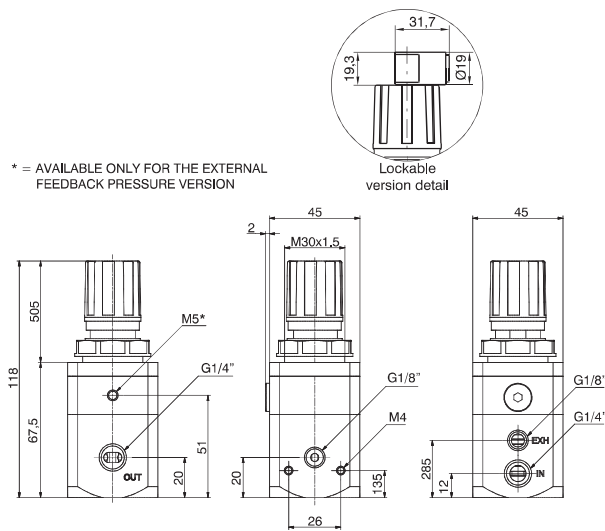

Size 1

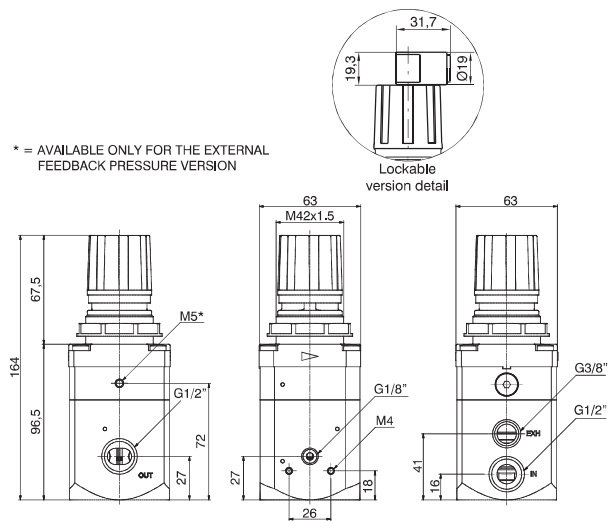

Size 3



Characteristic curves

2

AIR TREATMENT

Flow rate curves

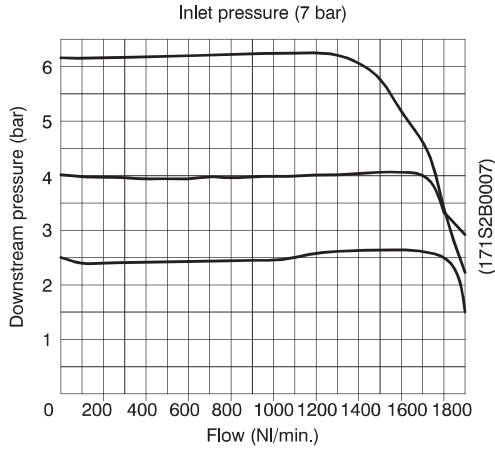

Size 1

Flow rate curves

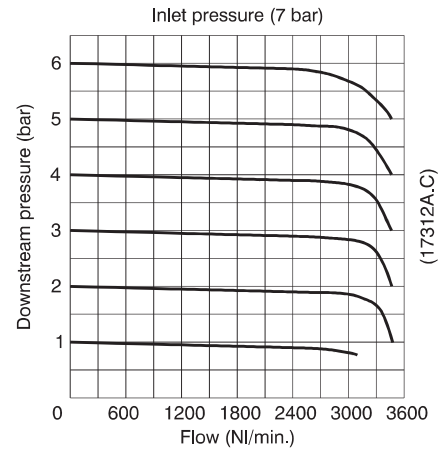

Size 3

Adjustment characteristic

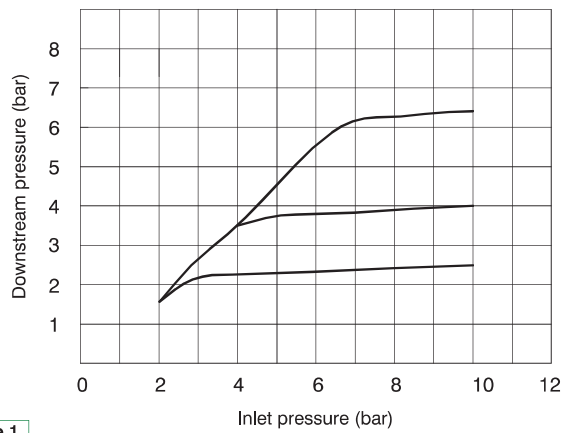

Size 1

Adjustment characteristic

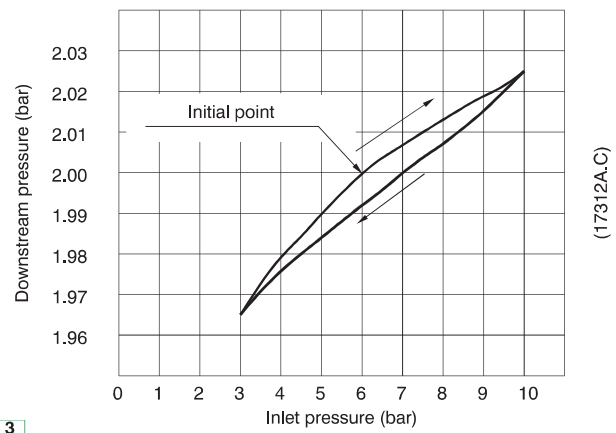

Size 3

Exhaust flow rate curves

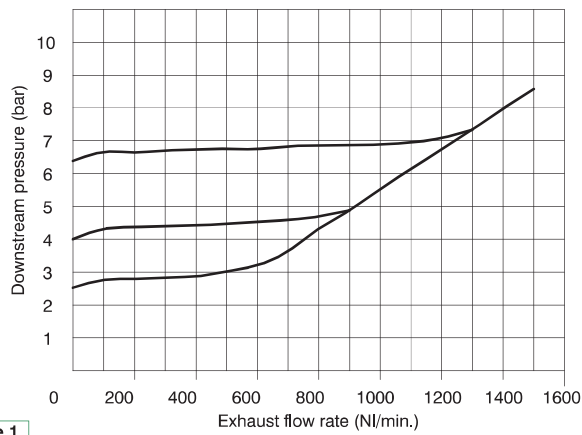

Size 1

Exhaust flow rate curves

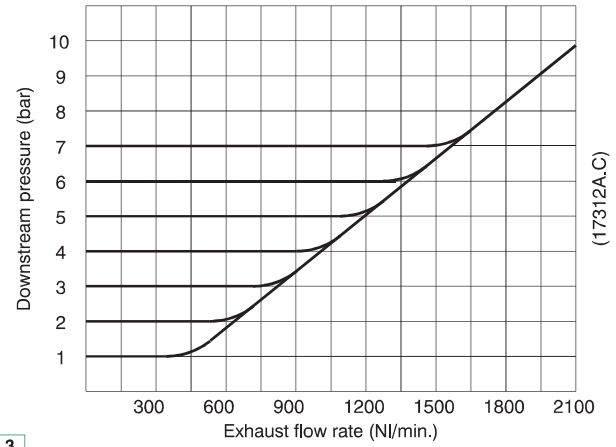

Size 3