

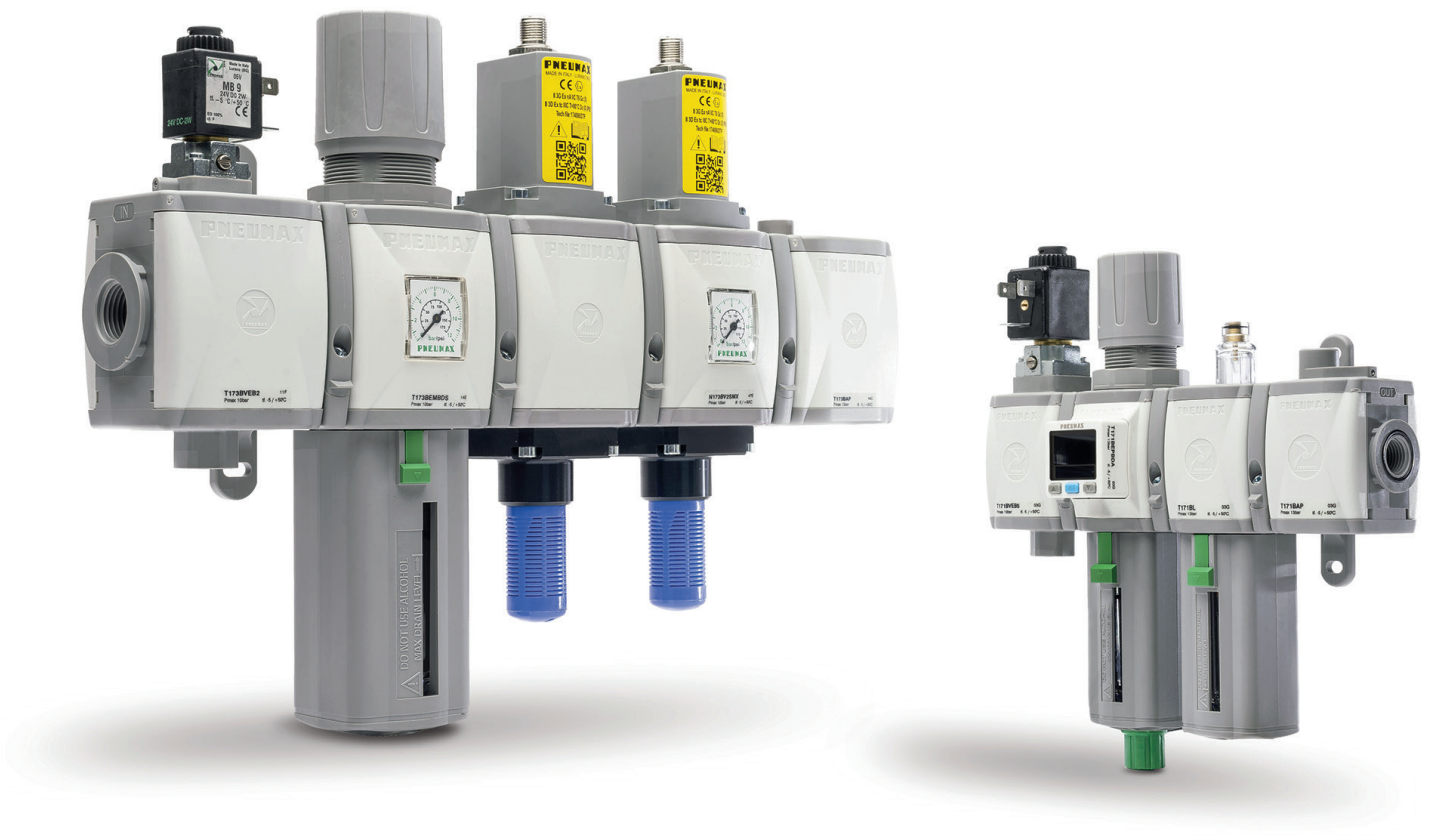

PNEUMAX



SERIES 1700 AIR TREATMENT



Air service units, series 1700

- Modular system
- Available for 4 sizes with connections from 1/8" to 1"
- ATEX certification (II 2GD o II 3GD) on request



2

AIR TREATMENT

Construction and working characteristics

1700 air treatment series includes a wide range of elements for individual use or modular assembling.

Available in 4 sizes e connections from 1/8" to 1".

The bowls are made in zinc alloy body with zinc alloy integrated connections, technopolymer with integrated metal connections for size 1 and aluminium with integrated aluminium connections for sizes 2, 3 and 4.

The bowls are in Nylon, with technopolymer protection for sizes 1, 2, 3 (also available for size 1 without protection). The bowls are in metal with condensation drain display for size 4.

Filters can be equipped with manual or semiautomatic condensation drain; furthermore it's possible to install the automatic draining device inside the bowl.

Wall mounting by means of screws directly through the body and hidden by protective covers.

The pressure regulator handle is lockable in the desired position, the shut-off valves are lockable with a maximum of three pad-locks to prevent accidents or damages due to unauthorized operation.

The lubricator oil flow is adjustable with proper handle and it is visibly checked through the sight dome.

The progressive start-up valve, pneumatically or electropneumatically controlled, allows air supply to the circuit progressively and with adjustable time. The accessories like panel mounted brackets, pressure gauges with different scales and diameters and the air intake blocks are completing the range. They are assembled between the elements to get filtered or filtered non-lubricated air in the system.

Instruction for installation and operation

Pay attention to install a group or a single component with air flow direction according to the arrows and to the following sequence: filter, pressure regulator, lubricator and with bowls downwards. The group can be fixed to the wall by removing the covers, which can be installed again after fixing for covering the screws. Do not exceed the recommended torque while assembling the connectors.

Do not exceed the recommended air pressure and temperature limits. The moisture should not exceed the level marked on the bowl and it can be drawn off and carried by a flexible tube of Ø 6/4 directly connected to the discharge valve handle.

The pressure should be set from minimum to maximum, rotating the adjusting handle clockwise.

As lubricant, we suggest to use oil class FD22 or HG32. Verify that the lubricator is not fed with a flow lower than the minimum operational.

To set the oil flow rotate the proper adjusting handle in order to get one drop of oil every 300-600 liters of air.

The oil flow will be kept automatically and proportionally to the air flow. The oil can be refilled by mean of proper plug or directly into the bowl after having de-pressurized the system. Do not exceed the maximum level indicated on the bowl. For opening the shut-off valve push and rotate clockwise the operating handle. For closing it and consequently discharging the down stream line, rotate the handle counter-clockwise.

Maintenance

Clean the bowls with water and detergent. Do not use alcohol.

The filter element made with HPDE is reusable by blowing and cleaning it with proper detergent. For replacing or cleaning it, remove the bowl and unscrew the baffle spins.

Replace the pressure regulator diaphragm whenever the operation is not correct or there is a continuous air leaking through the relieving (over pressure discharge); reinstall the adjusting mechanism support, locking it with about 8 Nm torque. In case it is necessary to replace the lubricator transparent dome, tight it at 5 Nm torque maximum.



▶ Pressure regulators for manifold



- ▶ Diaphragm pressure regulator with relieving.
- ▶ Available with 2 front outputs connections G1/8"
- ▶ Available in four pressure ranges up to 12 bar
- ▶ Ring nut for panel mounting
- ▶ Available with integrated pressure gauge on the top of adjusting knob
- ▶ Air supply can be applied by both directions (Right or Left)
- ▶ Max. 6off pressure regulators in manifold configuration
- ▶ Atex certification (II 2GD) on request

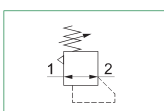

Note

For installations where a more accurate and constant pressure is required, the unit should be installed as close as possible to the point of use.

2

AIR TREATMENT

Technical characteristics	Size
	Size 1
Body and connections type	Zinc alloy body, integrated zinc alloy connections
IN / OUT connections	G1/8" - G1/4"
Assembly configuration	Stand alone Panel mounting Panel mounted with M4 screws With fixing bracket
Assembly position	Indifferent
Pressure range (bar)	0 - 2 / 0 - 4 / 0 - 8 / 0 - 12
Regulation	Manual push and lock with pressure Manual lockable with accessories (only for version without pressure gauge)
Pressure measurement	Integrated pressure gauge on the top of adjusting knob (optional)
Max. fittings torque IN / OUT connections	G1/8" metal: 15 G1/4" metal: 20

Operational characteristics	Size
	Size 1
Maximum working pressure (bar)	13
Minimum working pressure (bar)	0,5
Working temperature (°C)	-5 ÷ +50

Weights	Size
	Size 1
Zinc alloy body version (g)	380

Order codes

17 **0B2A** . **D** . **K**

Size, body and connections	
0B2A	Zinc alloy body, connections G1/8"
0B2B	Zinc alloy body, connections G1/4"
0M2A	Zinc alloy body, connections G1/8" with integrated pressure gauge
0M2B	Zinc alloy body, connections G1/4" with integrated pressure gauge
Pressure range	
A	0 - 2 bar
B	0 - 4 bar
C	0 - 8 bar
D	0 - 12 bar
Options	
	: Standard
K	Lockable version (only for version without pressure gauge)
U	Lockable version with universal key (only for version without pressure gauge)

2

Example: 170B2A.D.K

Size 1 pressure regulators for manifold, Zinc alloy body, G1/8" connections, 0 - 12 bar, without pressure gauge, Lockable version

Dimensions

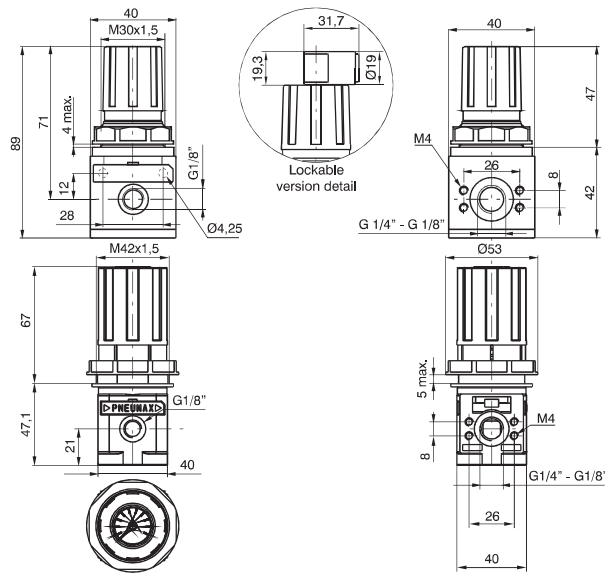

Size 1

Characteristic curves

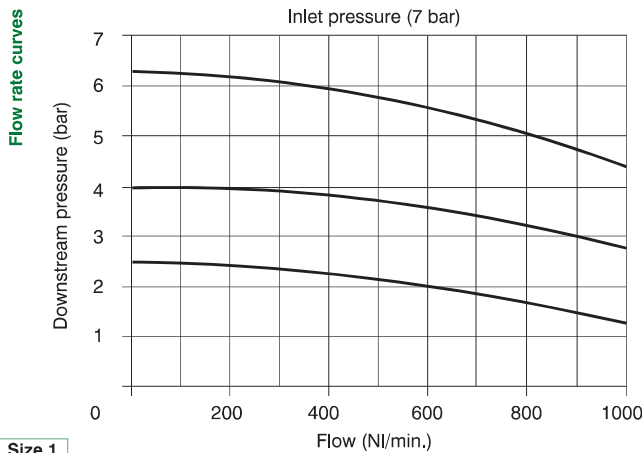

Size 1

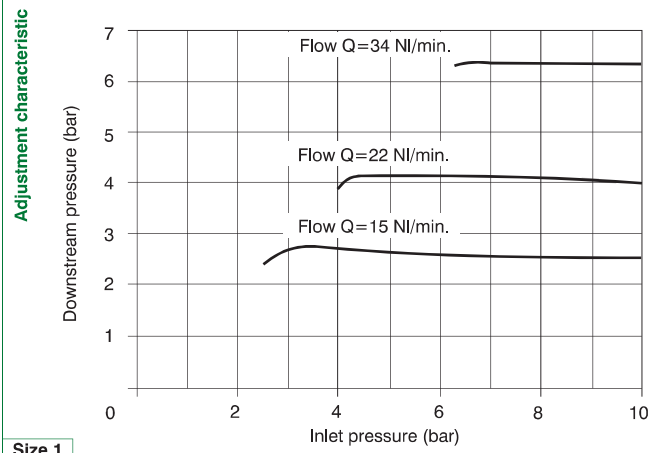

Size 1