

178 Series Valves



800.909.4988
info@rankinusa.com

RANKIN 
COMPONENTS THAT AUTOMATE

DESCRIPTION

Solenoid valve 2 way normally closed with assisted-lift diaphragm in stainless steel AISI 316

CONSTRUCTION

Body and cover	AISI 316
Armature tube	AISI 316
Plunger and core	AISI 430FR
Springs	AISI 302
Shading ring	Silver
Seal material	FPM
	NBR (on request)



FEATURES



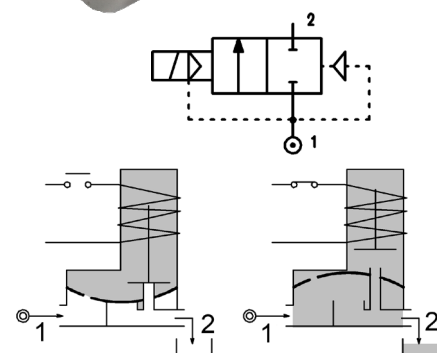

- Maximum allowable pressure PS 16bar^③
- Maximum fluid viscosity 25cSt (mm²/s)
- Ambient temperature: from -10°C to +80°C according to the coil
- Preferred mounting position with vertical coil above

- OPTIONS:**
- UL[®] certified coils
 - NPT connections
 - ATEX Ex d coils
 - Degreased for use with oxygen



CODE ① ②	Connection G ISO 228	Orifice mm Ø	Kv m ³ /h	Differential pressure bar			Nominal power	Coil		Seal ①	Temp. range °C
				Min	Max			Series	Width		
					AC	DC					
E178CV15///...	3/8"	15	2.4	0	14	6	10W	2	30	FPM=V	-10 +140
					-	14	27W	5	36		
E178DV16///...	1/2"	16	3	0	14	6	10W	2	30		
					-	14	27W	5	36		
E178EV20///...	3/4"	20	3.6	0	14	6	10W	2	30		
					-	14	27W	5	36		
E178FV25///...	1"	25	8.4	0	14	3	10W	2	30		
					-	8	14W	5	36		
					-	14	27W	5	36		
E178GV35///...	1"1/4	35	18	0	8	-	10W	2	30		
					14	2	14W	5	36		
					-	7	27W	5	36		
E178HV40///...	1"1/2	40	19.2	0	8	-	10W	2	30		
					14	2	14W	5	36		
					-	7	27W	5	36		

- ① Seal
- ② Coil
- ③ The maximum allowable pressure PS for steam is 2,5bar (gauge pressure)

COILS ②	Alternating Current 50/60Hz (V)							Direct Current (V)		Electrical connection	Connectors
	12	24	48	110	220 230	240	380	12	24		
Series 2 Width 30-10W	20A	20B	20C	20D	20E	20F	20G	200	201	DIN 43650A	PG9 code 10349000 or PG11 code 10349001
Series 5 Width 36-14W	-	U55B 	-	U55D 	-	U55F 	-	U550 	U551 		
Series 5 Width 36-27W	52A	52B	52C	52D	52E	52F	52G	520	521		

DESCRIPTION
 Insulation class
 Series 2 =F Series 5=H
 Voltage tolerance
 AC +15% -10%
 DC ± 10%
 Protection class
 IP65 with connector fitted
 IP00 without connector

OPTIONS
 Class H insulation (series 2)
 Cable attached
 Special coil voltage
 Special coil powers
 certified coils

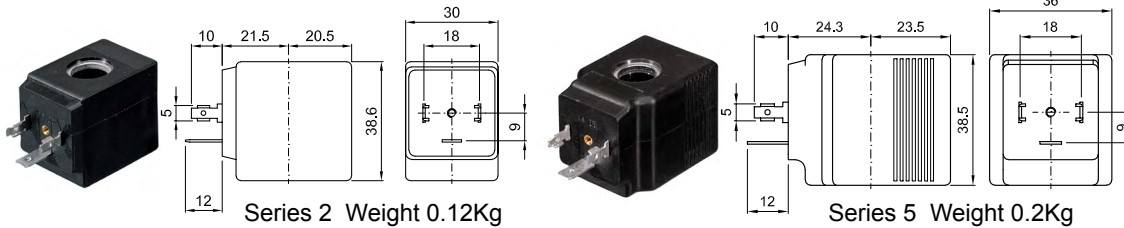

(for coil details see section 8)

SPARE PARTS LIST

1. Coil
2. Armature tube
3. Armature tube OR
4. Body OR
5. Diaphragm assembly+plunger

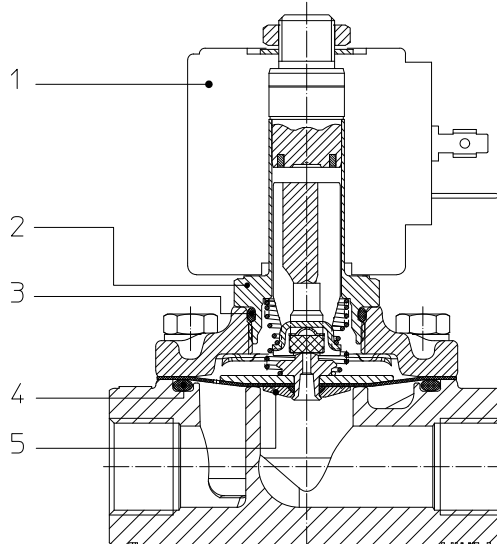

OVERALL DIMENSION

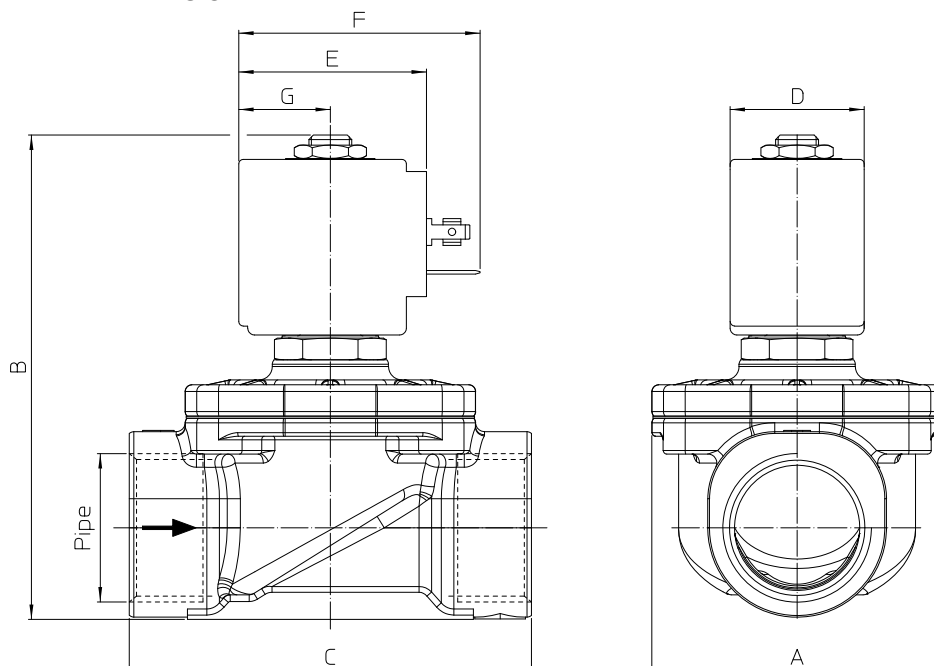

PIPE	A	B	C
G3/8"	52	92	68
G1/2"	52	92	68
G3/4"	58	100	75
G1"	65	109	90
G1"1/4	94	126	128
G1"1/2	94	126	128

COIL TYPE	D	E	F	G
Series 2 30mm	30	42	54	20.5
Series 5 36mm	36	48	60	23.5