

# 205 Series Valves



800.909.4988  
info@rankinusa.com

**RANKIN**   
COMPONENTS THAT AUTOMATE

## DESCRIPTION

Solenoid valve 2 way normally open  
direct acting poppet type

## CONSTRUCTION

Body	Brass
Armature tube	Brass
Plunger and core	AISI 430FR
Springs	AISI 302
Seal material	NBR - FPM - EPDM

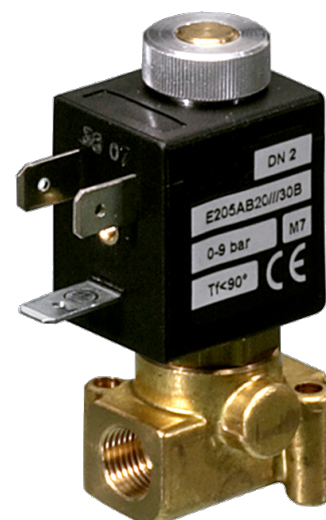

**2**

## FEATURES

Maximum allowable pressure PS 50bar<sup>④</sup>  
Maximum fluid viscosity 25cSt (mm<sup>2</sup>/s)  
Ambient temperature: from -10°C to +80°C according to the coil  
Universal mounting position

**OPTIONS:** Stainless steel armature tube  
Electroless nickel plating  
Series 7 explosion proof coil according to ATEX - EExmII  
c  us certified coils

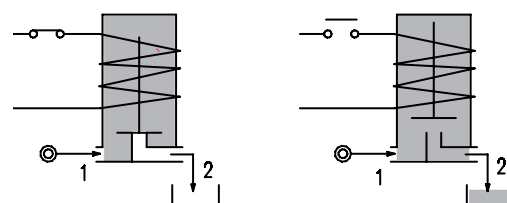
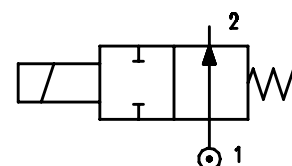

**ON REQUEST:** Versions for use with fluid temperature at -40°C  
Manual override

CODE ① ②	Connection G ISO 228	Orifice mm	Kv m <sup>3</sup> /h	Differential pressure bar			Nominal power			Coil		Seal ①	Temp. range °C
				Min	Max		AC Inrush	VA Holding	DC Watt	Series	Width		
E205A...12///...	1/8"	1.2	0.04	0	19	19	12	8	6.5	3	22	NBR=B	-10 +90
E205A...15///...		1.5	0.06	0	14	14						EPDM=E	-10 +140
E205A...20///...		2	0.09	0	8	8						FPM=V	-10 +140
E205A...25///...		2.5	0.14	0	4.5	4.5							
E205A...31///...		3.1	0.19	0	2.5	2.5							

① Seal Example: E205AB20///30B NBR seal

② Coil Coil 24V 50/60Hz

③ Direct current (DC) series 3 coil available only without UL certification

④ The maximum allowable pressure PS for steam is 2.5bar (gauge pressure)

COILS ②	Alternating Current 50/60Hz (V)							Direct Current (V)			Electrical connection	Connectors
	12	24	48	110	220 230	240	380	12	24	48		
Series 3 Width 22	30A	30B	30C	30D	30E	30F	30G	300	301	302	DIN 46244	PG9 code 10348000

**DESCRIPTION**  
 Class F insulation  
 Voltage tolerance  
 AC +15% -10%  
 DC ± 10%  
 Protection class  
 IP65 with connector fitted  
 IP00 without connector  
 Continuous service ED100%

**OPTIONS**  
 Class H insulation  
 Cable attached  
 Special coil voltage  
 Special coil powers  
 CE certified coils

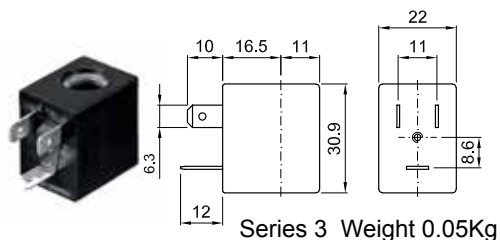

(for coil details see section 8)

### SPARE PARTS LIST

1. Coil fixing nut
2. Coil
3. Seal assembly
4. Armature tube assembly

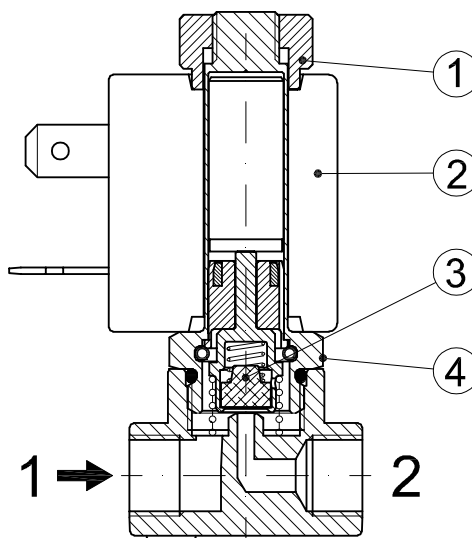

### OVERALL DIMENSION

