

211 Series Valves

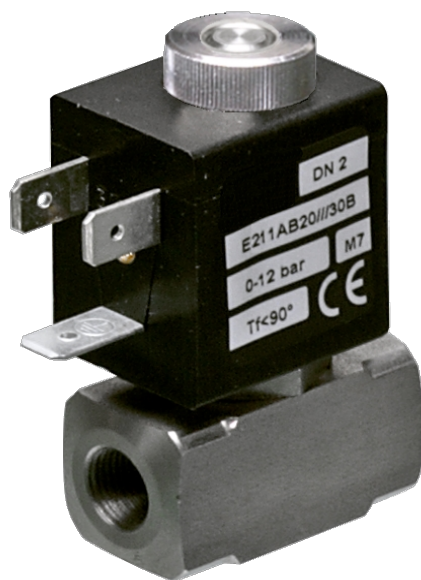

800.909.4988
info@rankinusa.com

RANKIN 
COMPONENTS THAT AUTOMATE

DESCRIPTION

Solenoid valve 2 way normally open direct acting poppet type

CONSTRUCTION

Body	AISI 303
Armature tube	AISI 303
Plunger and core	AISI 430FR
Springs	AISI 302
Seal material	NBR - FPM - EPDM

FEATURES

Maximum fluid viscosity 25cSt (mm²/s)

Ambient temperature: from +14°F to +176°F according to the coil

Universal mounting position

OPTIONS: Series 7 explosion proof coil according to

 ATEX II 2G Ex mb IIC T6, T5, T4 Gb
II 2D Ex mb IIC T85°C, T100°C, T135°C Db
similar to NEC 505 Div.1 Class II IIC T6

Version for use with industrial oxygen

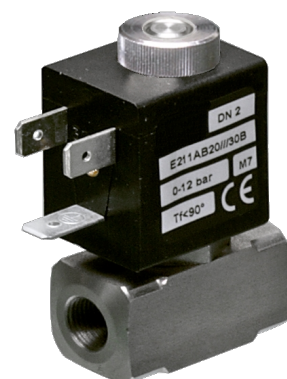

ON REQUEST: Versions for use with fluid temperature at -40°C
Manual override

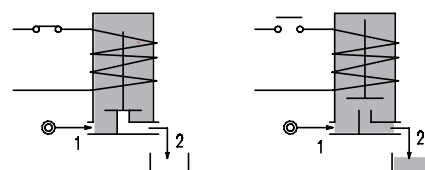
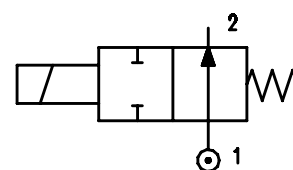

2



CODE <small>① ②</small>	Port Size NPT	Orifice Size (in) (mm)		Flow Factor Cv (gpm)	Operating Pressure Differential (M.O.P.D.) ③				Nominal power			Coil		Seal ①	Temp. range (°F)	
					Min	Max		Inrush	Holding	DC (W)	Series	Width (mm)				
						AC (psi)	AC (bar)						DC (psi)			DC (bar)
E211AN...12///...	1/8	0.047	1.2	0.046	0	246	17	246	17	12	8	6.5	3	22	NBR=B +14 +194	
E211AN...15///...		0.059	1.5	0.069	0	188	13	188	13							
E211AN...20///...		0.079	2	0.104	0	101	7	101	7							
E211AN...25///...		0.098	2.5	0.162	0	50	3.5	50	3.5							
E211AN...31///...		0.118	3	0.220	0	29	2	29	2							
E211AN...12///...	1/8	0.047	1.2	0.046	0	246	17	246	17	15	11	8	4	30	EPDM=E +14 +284	
E211AN...15///...		0.059	1.5	0.069	0	188	13	188	13							
E211AN...20///...		0.079	2	0.104	0	101	7	101	7							
E211AN...25///...		0.098	2.5	0.162	0	50	3.5	50	3.5							
E211AN...31///...		0.118	3	0.220	0	29	2	29	2							

- ① Seal Ordination example: E211ANB15///U35B NBR seal, connection 1/8 NPT
- ② Coil Coil 24V 60Hz certified  and marked 
- ③ Safe Working Pressure:725 psi. Is the line or system pressure to which the valve may be subjected without being damaged.
The maximum allowable pressure PS for steam is 36 psi.
- ④ Direct current (DC) series 3 coil available only without UL certification

COILS Code ②	Alternating Current						Direct Current				Electrical connection	Connectors
	24V		120V		240V		12V		24V			
Series 3 Width 22mm	U35B c US	30B	U35D c US	30D	U35F c US	30F	-	300	-	301	DIN 46244	PG9 code 10348000
Series 4 Width 30mm	-	40B	-	40D	-	40F	U450 c US	400	U451 c US	401	DIN 43650A	PG9 code 10349000

DESCRIPTION
 Class F or H insulation
 Voltage tolerance $\pm 10\%$
 Protection class:
 IP65 with connector attached
 IP00 without connector
 Continuous service ED100%

OPTIONS
 Cable attached
 Special coil voltage
 Special coil powers

OVERALL DIMENSIONS

inches (mm)

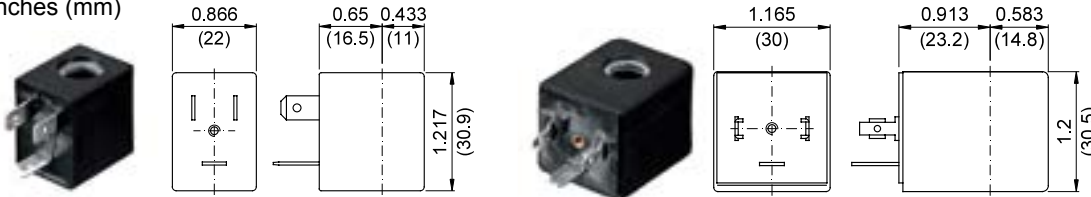

Series 3 Weight 0.11lb (0.05Kg)

Series 4 Weight 0.22lb (0.1Kg)

FOR COIL SPECIFICATION SEE SECTION 6

SPARE PARTS LIST

1. Coil fixing nut
2. Coil
3. Seal assembly
4. Armature tube assembly

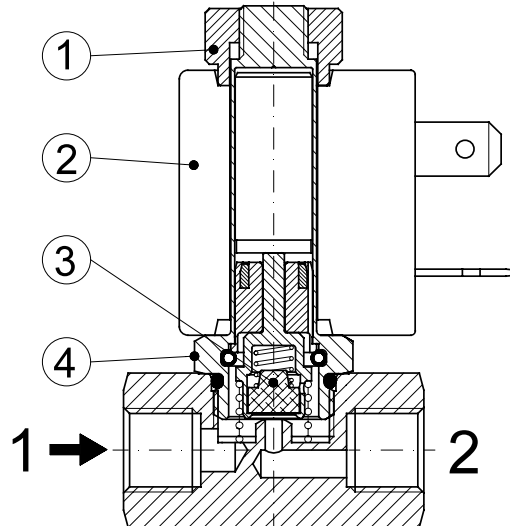

OVERALL DIMENSIONS

inches (mm)

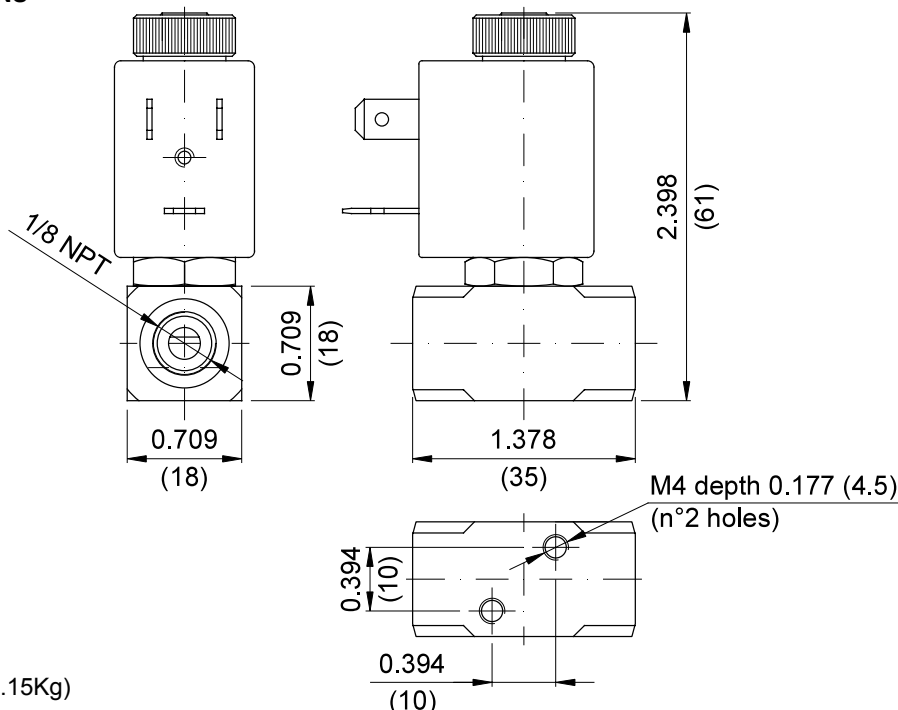

Weight = 0.33lb (0.15Kg)