

320 Series Valves



800.909.4988
info@rankinusa.com

RANKIN 
COMPONENTS THAT AUTOMATE

COILS Code ②	Alternating Current				Direct Current		Electrical connection	Connectors
	12V	24V	110-120V	240V	12V	24V		
Series 5 Width 36mm	52A	52B	52D	52F	520	521	DIN 43650A	PG11 code 10349001

DESCRIPTION
 Insulation class H
 Voltage tolerance ±10%
 Protection class:
 IP65 with connector attached
 IP00 without connector
 Continuous service ED100%

OVERALL DIMENSIONS

inches (mm)

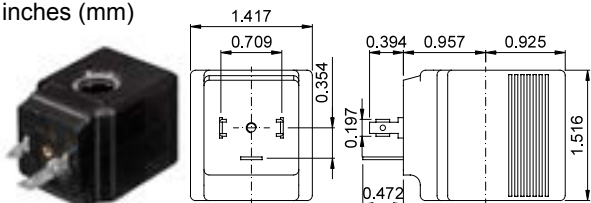

Series 5 Weight 0.44lb (0.2Kg)

OPTIONS

Cable attached
 Special coil voltage
 Special coil powers

SPARE PARTS LIST

1. Coil fixing nut
2. Coil
3. Armature tube assembly

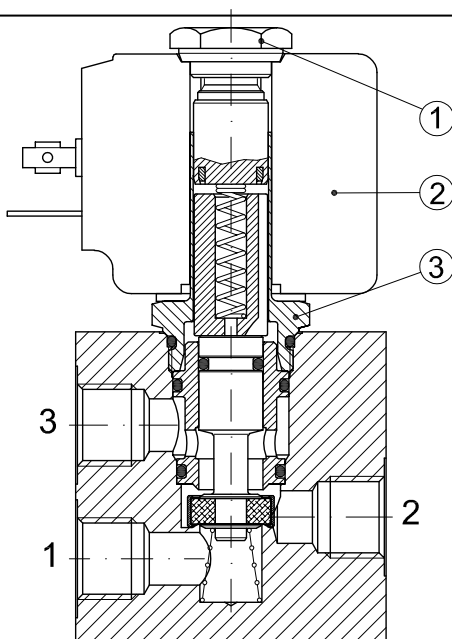

OVERALL DIMENSION

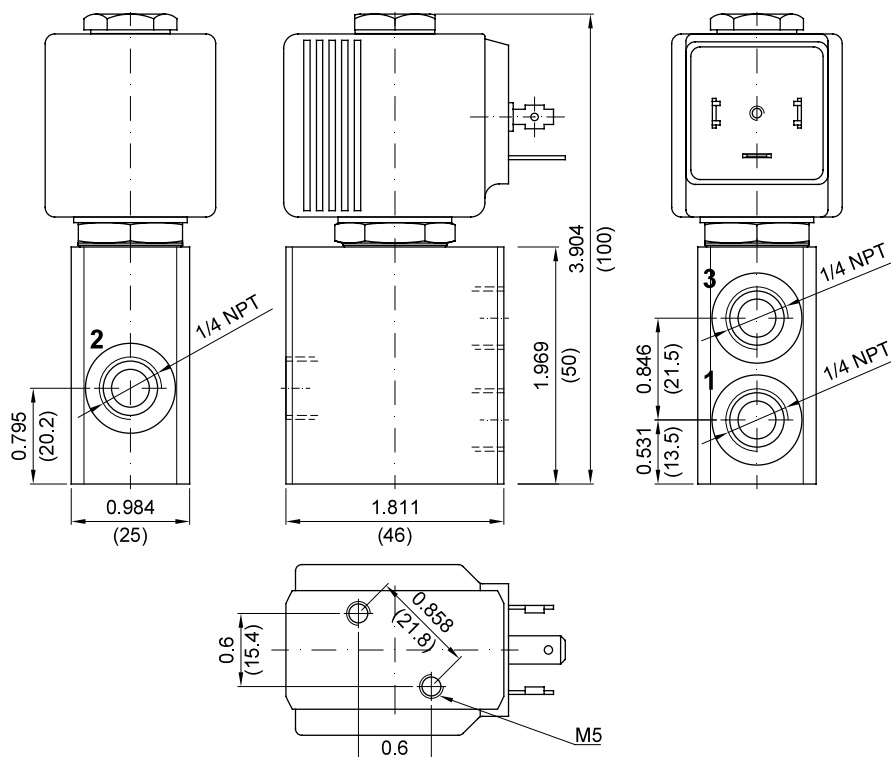

Weight=0.95lb (0.43Kg)