

AW Series Cylinders

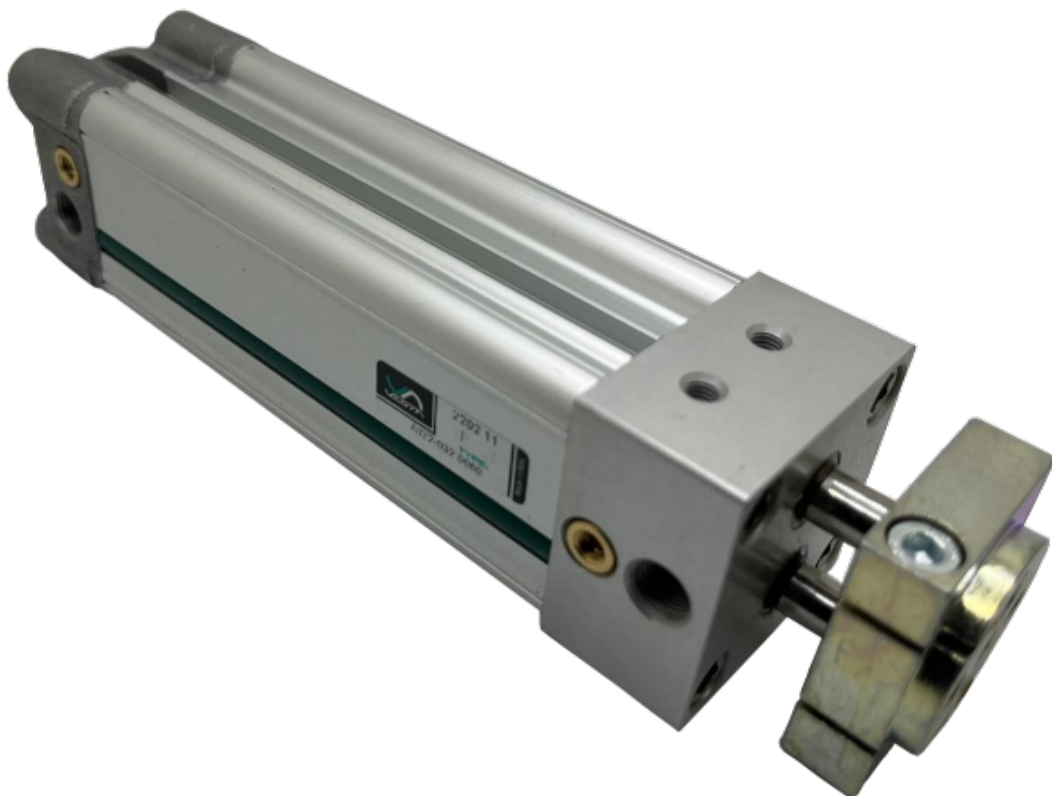

800.909.4988
info@rankinusa.com

**ANTI-ROTATION CYLINDERS
CILINDRI ANTIROTAZIONE**
SERIE AW ..
TECHNICAL FEATURES / CARATTERISTICHE COSTRUTTIVE

VESTA pneumatic cylinders series **AW** are available with twin or triple piston rods. They feature reliability, high resistance to side movement and are manufactured to meet the needs of modern flexible automation.

The materials of construction have been carefully selected to ensure high performance.

All piston rods are guided on self-lubricated bearings, giving low friction and a high load capacity.

Magnetic pistons allow the use of magnetic switches on all models.

Fully adjustable cushioning is featured on each cylinder with micrometric control. Lubrication is not required.

Telescopic piston rods with hollow bores enable the user to transport air or vacuum signals through the length of the piston rod.

*Gli attuatori pneumatici appartenenti alla serie **AW** a due e tre steli, nascono per garantire prestazioni e durata notevoli del cilindro anche in presenza di carichi sullo stelo che ne determinano un momento torcente o flettente, incrementando in maniera considerevole la resistenza a tali sollecitazioni. La scelta di materiali di prima qualità, l'accuratezza nelle lavorazioni e il controllo del prodotto finito garantiscono una perfetta funzionalità dello stesso.*

Gli steli sono guidati su boccole autolubrificanti a lunga durata, basso coefficiente d' attrito ed elevata capacità di carico; il pistone è guidato e magnetico di serie, onde consentire su tutti i modelli l'uso di fincorsa.

*Ogni cilindro può essere utilizzato anche con aria non lubrificata ed è dotato di ammortizzatori pneumatici con regolazione micrometrica. All'interno della serie **AW** spiccano particolarmente i cilindri a steli cavi che, oltre a garantire la non rotazione dello stelo, consentono l'utilizzo di aria o vuoto attraverso gli steli stessi (vedi gli esempi di pagina A-75).*

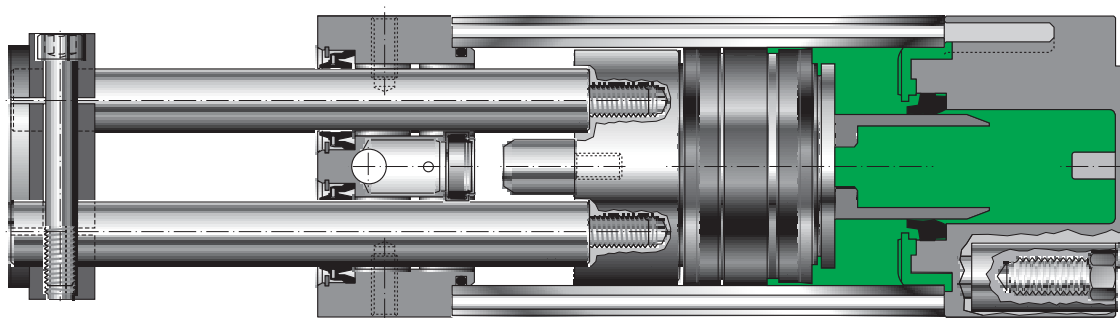

PRECAUTIONS BEFORE USE / RACCOMANDAZIONI PER L'INSTALLAZIONE

- Avoid impacts and abrasion of piston rods, or else the correct functioning of the anti-rotation cylinder can be endangered by uneven wear of the bearings or seals.
- Lubrication is not necessary, but if it provided, use only ISO VG 32 oil. Do not use engine oil or spindle oil.
- Before each pneumatic connection, clean tubes and fittings carefully.
- Evitare urti ed abrasioni degli steli, in caso contrario si comprometterebbe il buon funzionamento della stessa con anomale usure dei cuscinetti e delle guarnizioni.
- La lubrificazione non è necessaria, ma se prevista usare olio ISO VG 32. Non usare olio per motori o per mandrini.
- Prima di ogni collegamento pneumatico pulire accuratamente tubi e raccordi.

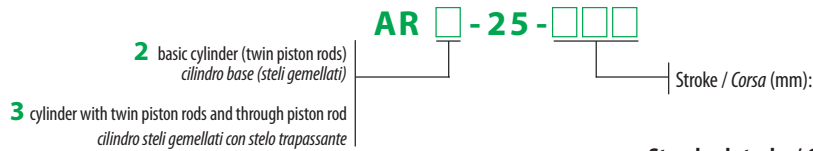

SERIE AR2 - AR3

TWIN PISTON RODS PNEUMATIC CYLINDERS Ø25 CILINDRI ANTIROTAZIONE A STELI GEMELLATI Ø25



Bore Alésaggio	Standard stroke / Corse Standard							
25	25	50	80	100	125	160	200	250
	•	•	•	•	•	•	•	•

TECHNICAL FEATURES

Heads Aluminium alloy.
Piston rods Stainless steel X5CrNi 1810.
Barrel Anodized aluminium.
Seals NBR rubber.
Cushioning Mechanical.

Environment temperature range -10 °C ÷ +80 °C.
Temperature range of medium 0 °C ÷ +40 °C.
Lubrication Not required.
Medium filtered air.
Max operating pressure 10 bar.

CARATTERISTICHE TECNICHE

Testate Lega di alluminio.
Steli Acciaio inox X5CrNi 1810.
Camicia Alluminio anodizzato.
Guarnizioni Tutte in NBR con profili antiusura e prelubrificate.
Ammortizzatori Meccanici.

Temperatura ambiente -10 °C ÷ +80 °C.
Temperatura fluido 0 °C ÷ +40 °C.
Lubrificazione Non necessaria.
Fluido Aria filtrata.
Pressione max d'esercizio 10 bar.

AR2-25-...

TWIN PISTON RODS BASIC CYLINDER; Ø25
CILINDRO BASE STELI GEMELLATI; Ø25

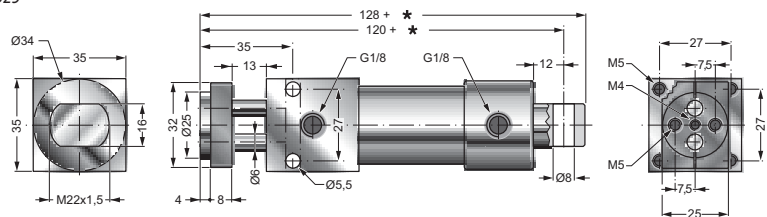
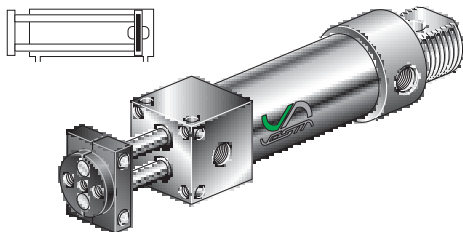

* = Stroke / Corsa

AR3-25-...

TWIN PISTON RODS+THROUGH PISTON ROD; Ø25
CILINDRO STELI GEMELLATI E PASSANTE; Ø25

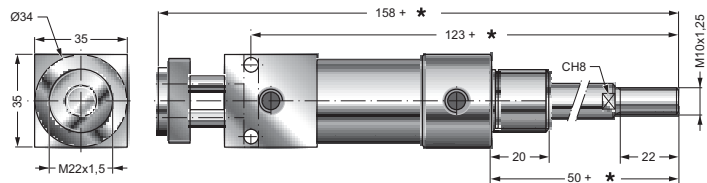
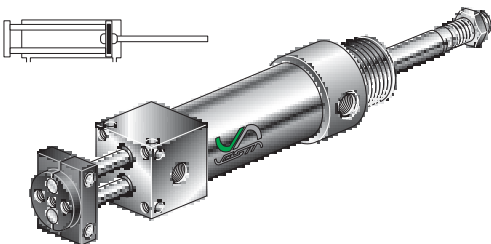

* = Stroke / Corsa

MAGNETIC SWITCHES FOR Ø 25 mm CYLINDER / FINECORSA MAGNETICI PER CILINDRI Ø 25 mm

FFS 01 VN

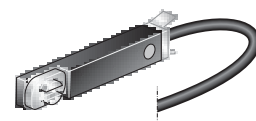
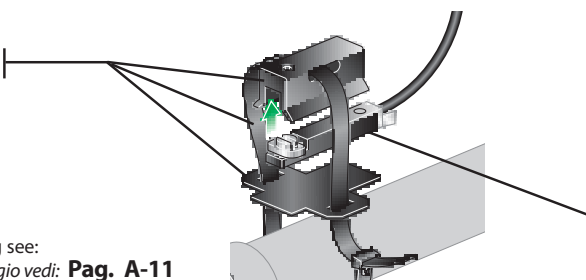

For magnetic switches features see:
Caratteristiche finecorsa magnetici vedi:

VNCR2, VNPR2, VNCE3, VNPE3. Pag. A-19

Instruction for mounting see:
Per le istruzioni di montaggio vedi: **Pag. A-11**

**TWIN PISTON RODS PNEUMATIC CYLINDERS
CILINDRI ANTIROTAZIONE A STELI GEMELLATI**

SERIE **AW2 - AW3 - AW4**

- 2 basic cylinder (twin piston rods)
cilindro base steli gemellati
- 3 cylinder with twin piston rods and through piston rod
cilindro steli gemellati con stelo trapassante
- 4 cylinder with twin piston rods and two through piston rods
cilindro steli gemellati con due steli trapassanti

AW - - - -

Bore / Alesaggio (mm):

- Ø32 **32**;
- Ø40 **40**;
- Ø50 **50**;
- Ø63 **63**;
- Ø80 **80**;
- Ø100 **100**.

Stroke
Corsa
(mm):

Bore Alesaggio	25	50	80	100	125	160	200	250	300	350	400	450	500
32	•	•	•	•	•	•	•	•	•	•	•	•	•
40	•	•	•	•	•	•	•	•	•	•	•	•	•
50	•	•	•	•	•	•	•	•	•	•	•	•	•
63	•	•	•	•	•	•	•	•	•	•	•	•	•
80	•	•	•	•	•	•	•	•	•	•	•	•	•
100	•	•	•	•	•	•	•	•	•	•	•	•	•

Features of reed switches see:
Caratteristiche finecorsa magnetici: **Pag. A-19.**

TECHNICAL FEATURES

Heads Aluminium alloy.
Piston rods Stainless steel X20 Cr 13.
Barrel Extruded profiled aluminium tube.
Seals NBR rubber and polyurethane.
Cushioning Pneumatic adjusting cushions.

Environment temperature range -10 °C ÷ +80 °C.
Temperature range of medium 0 °C ÷ +40 °C.
Lubrication Not required.
Medium filtered air.
Max operating pressure 10 bar.

CARATTERISTICHE TECNICHE

Testate Lega di alluminio.
Steli Acciaio inox X20 Cr 13.
Camicia Tubo profilato ed anodizzato d' alluminio.
Guarnizioni In NBR e poliuretano.
Ammortizzatori Pneumatici regolabili progressivi.

Temperatura ambiente -10 °C ÷ +80 °C.
Temperatura fluido 0 °C ÷ +40 °C.
Lubrificazione Non necessaria.
Fluido Aria filtrata.
Pressione max d'esercizio 10 bar.

* = Stroke / Corsa

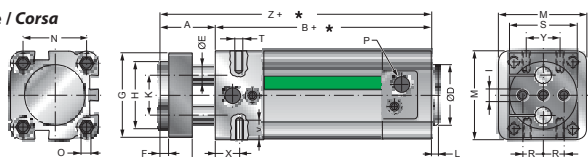

Bore Alesaggio	A	B	C	ØD	ØE	F	G	ØH	ØI	L	M	N	ØO	ØP	R	S	ØT	V	W	X	Y	Z	K
32	26	102	15	30	8	4	40	32	M6	4	45	32,5	M6	G1/8	9,5	32	M5	10	11	15	16	128	18
40	30	112	15	35	10	4	45	40	M8	4	55	38	M6	G1/4	11,5	40	M6	10	15	17,5	21	142	21
50	34	117	18	40	12	5	55	50	M8	4	65	46,5	M8	G1/4	15	50	M8	12	16	16	24	151	26
63	36	124	22	45	16	5	70	63	M10	4	80	56,5	M8	G3/8	19	63	M8	12	14	18	33	160	35
80	38	136	22	45	20	5	95	80	M12	4	100	72	M10	G3/8	25	80	M10	18	16	19	40	174	46
100	38	143	22	55	20	5	115	100	M12	4	115	89	M10	G1/2	35	100	M10	18	16	19	58	181	70

**TWIN PISTON RODS BASIC CYLINDER
CILINDRO BASE STELI GEMELLATI**

AW2-...-...

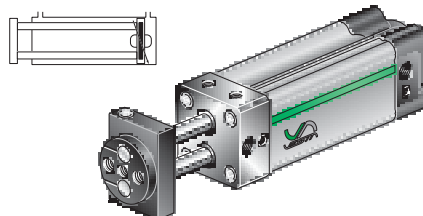

* = Stroke / Corsa

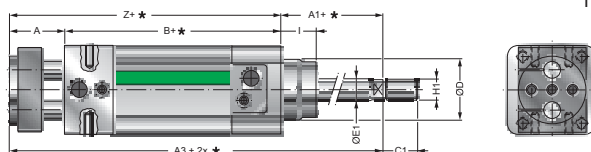

Bore Alesaggio	A	A1	A3	B	C1	CH	ØD	ØE1	I	ØH1
32	26	26	154	102	20	10	30	12	18	M10x1,25
40	30	30	172	112	24	13	35	16	21,5	M12x1,25
50	34	37	188	117	32	17	40	20	28	M16x1,5
63	36	37	197	124	32	17	45	20	28,5	M16x1,5
80	38	46	220	136	40	21	45	25	34,5	M20x1,5
100	38	51	232	143	40	25	55	30	38	M20x1,5

**TWIN PISTON RODS CYLINDER+THROUGH PISTON ROD
CILINDRO STELI GEMELLATI+STELO TRAPASSANTE**

AW3-...-...

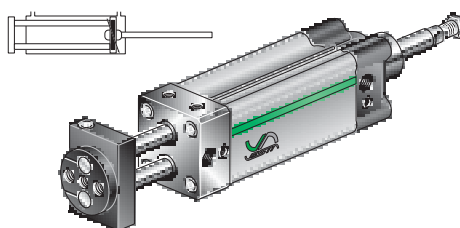

* = Stroke / Corsa

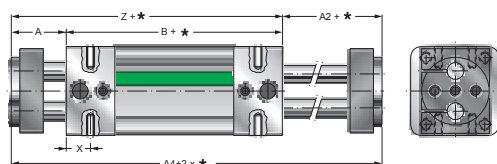

Bore Alesaggio	A	A2	A4	B	X	Z
32	26	26	154	102	15	128
40	30	30	172	112	17,5	142
50	34	34	185	117	16	151
63	36	36	196	125	18	160
80	38	38	212	136	19	174
100	38	38	219	143	19	181

**CYLINDER THROUGH TWIN PISTON RODS
CILINDRO STELI GEMELLATI PASSANTI**

AW4-...-...

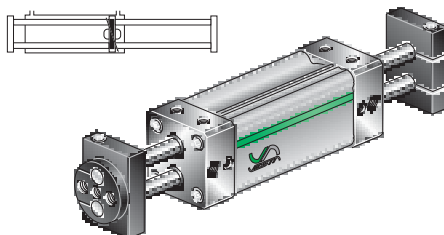



TRANSVERSE FORCE GRAPH AND TORQUE GRAPH AW2 SERIES
DIAGRAMMI DI FLESSIONE E MOMENTO TORCENTE SERIE AW2

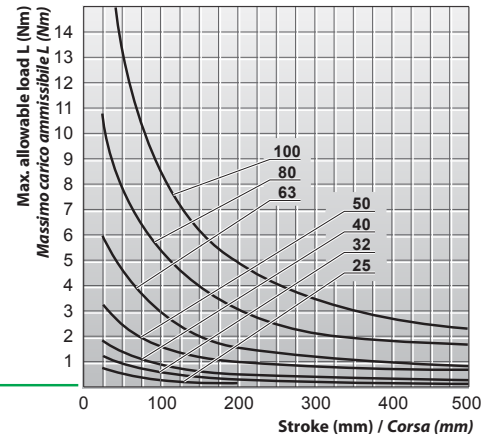
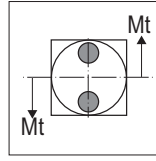
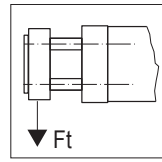
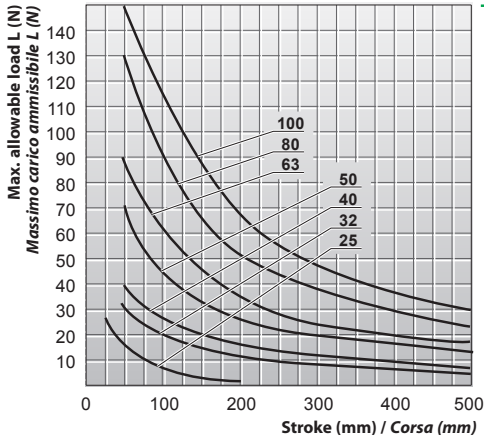

BENDINGS MOMENTS GRAPH AW2 SERIES
DIAGRAMMI DI FLESSOTORSIONE SERIE AW2

Maximum allowable load F (N)
 Massimo carico F (N)

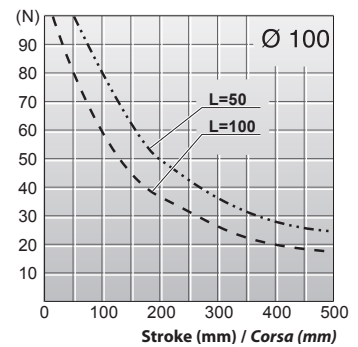
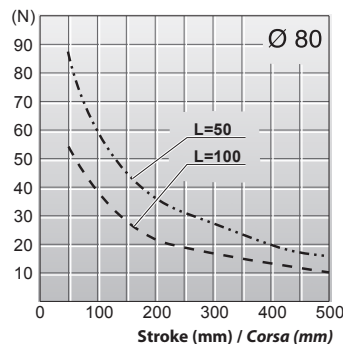
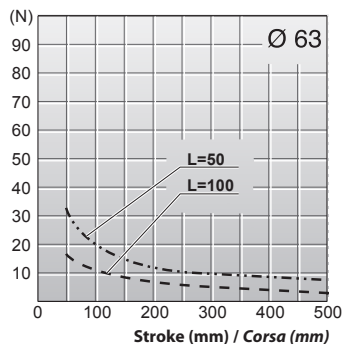
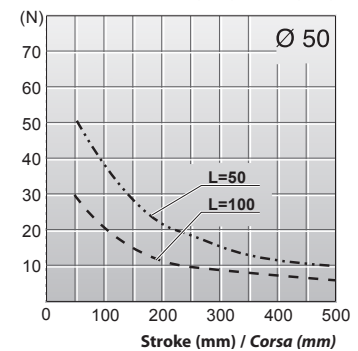
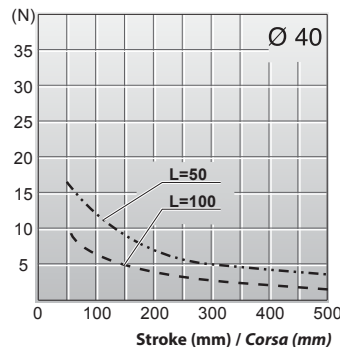
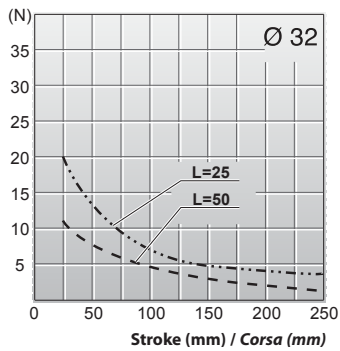
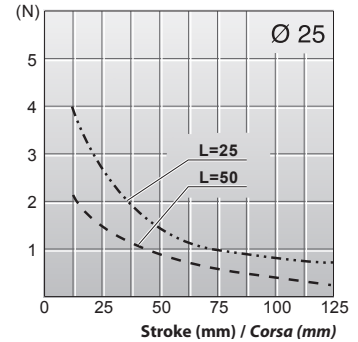
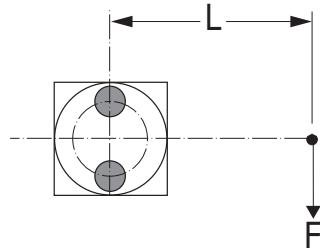

FIXING ACCESSORIES FOR AW2, AW3 AND AW4 CYLINDER / ACCESSORI DI FISSAGGIO PER CILINDRI AW2, AW3 E AW4

For fixing accessories on double piston roded units, please contact our technical sales department.
The accessories can be mounted on the profiled tube or on the end-caps using standard fixings, see pp. **A-22 ÷ A-26**.

*Per i fissaggi da applicare alla testata a doppio stelo si prega di consultare il nostro ufficio tecnico-commerciale.
I fissaggi che possono essere montati sulla camicia o sulla testata posteriore sono fissaggi standard specificati a pp. **A-22 ÷ A-26**.*

SEALS KIT - SG
KIT GUARNIZIONI DI RICAMBIO

Seals kit code = **Antirotation cylinder code + Bore + - SG:**
(The kit includes all seals).

Codice del kit = **Codice del cilindro antirotazione + Alesaggio + - SG:**
(Il kit comprende tutte le guarnizioni necessarie).

Example / Esempio: **AW3 50 - SG**

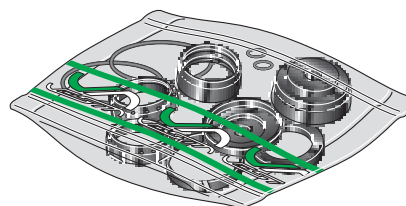



SERIE **AW6 - AW8**

TRIPLE PISTON RODS PNEUMATIC ANTIROTATION CYLINDERS CILINDRI ANTIROTAZIONE PNEUMATICI A TRIPLO STELO

AW - -

6 triple piston rods antirotation cylinder
cilindro base antirotazione a 3 steli

8 triple piston rods cylinder
with through piston rod
cilindro antirotazione a 3 steli
con stelo trapassante

Bore / Alesaggio
(mm):

- Ø32 **32**;
- Ø40 **40**;
- Ø50 **50**;
- Ø63 **63**.

Stroke / Corsa (mm):

Features of reed switches see:
Caratteristiche finecorsa magnetici: **Pag. A-19.**

Bore Alesaggio	Standard stroke / Corse Standard										
	25	50	100	160	200	250	300	350	400	450	500
32	•	•	•	•	•	•	•	•	•	•	•
40	•	•	•	•	•	•	•	•	•	•	•
50	•	•	•	•	•	•	•	•	•	•	•
63	•	•	•	•	•	•	•	•	•	•	•

TECHNICAL FEATURES

- End caps Aluminium alloy.
- Piston rods Stainless steel X20 Cr 13.
- Barrel Extruded profiled aluminium tube.
- Seals NBR rubber and polyurethane.

- Cushioning Micrometric control.
- Environment temperature range -10 °C ÷ +80 °C.
- Temperature range of medium 0 °C ÷ +40 °C.
- Lubrication Not required.
- Medium filtered air.
- Max operating pressure 10 bar.

CARATTERISTICHE TECNICHE

- Testate Lega di alluminio.
- Steli Acciaio inox X20 Cr 13.
- Camicia Tubo profilato ed anodizzato d' alluminio.
- Guarnizioni In NBR e poliuretano.

- Ammortizzatori Con regolazione micrometrica.
- Temperatura ambiente -10 °C ÷ +80 °C.
- Temperatura fluido 0 °C ÷ +40 °C.
- Lubrificazione Non necessaria.
- Fluido Aria filtrata.
- Pressione max d'esercizio 10 bar.

AW6-...-...

TRIPLE PISTON RODS BASIC CYLINDER
CILINDRO BASE CON 3 STELI

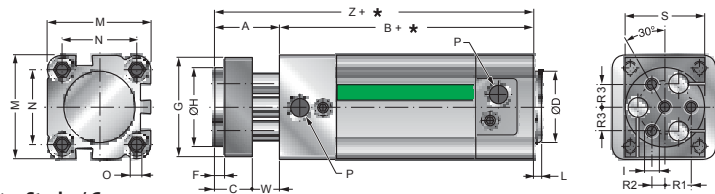
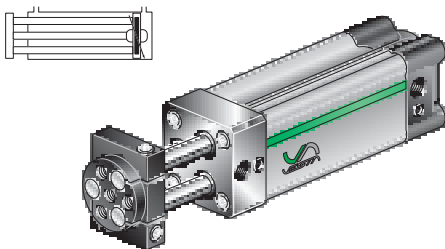

* = Stroke / Corsa

Bore Alesaggio	A	B	C	ØD	F	G	ØH	ØI	L	M	N	ØO	ØP	R1	R2	R3	S	W	Z	Stems diameter Diametro steli
32	26	102	15	30	4	40	32	M6	4	45	32,5	M6	G1/8	10	5	8,7	40	11	128	8
40	30	112	15	35	4	45	40	M8	4	55	38	M6	G1/4	12,5	6,3	9,3	40	15	142	12
50	34	117	18	40	5	55	50	M8	4	65	46,5	M8	G1/4	15,5	7,8	13,4	50	16	151	12
63	36	124	22	45	5	70	63	M10	4	80	56,5	M8	G3/8	19	9,5	15,2	63	14	160	16

AW8-...-...

TRIPLE PISTON RODS + THROUGH PISTON ROD
CILINDRO CON 3 STELI E STELO TRAPASSANTE

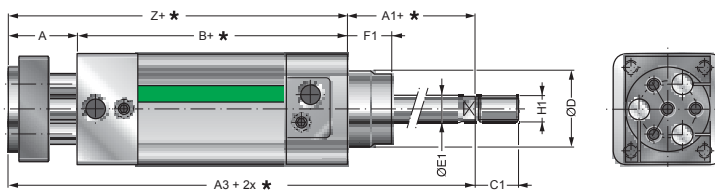
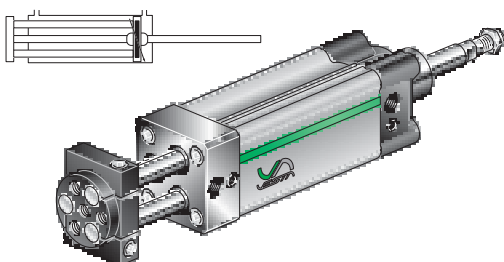

* = Stroke / Corsa

Bore Alesaggio	A	A1	A3	B	C1	CH	ØD	ØE1	F1	H1	Z
32	26	26	154	102	20	10	30	12	18	M10x1,25	128
40	30	30	172	112	24	13	35	16	21,5	M12x1,25	142
50	34	37	194	117	32	17	40	20	28	M16x1,5	151
63	36	37	197	124	32	17	45	20	28,5	M16x1,5	160

FIXING ACCESSORIES FOR AW6 AND AW8 CYLINDER / ACCESSORI DI FISSAGGIO PER CILINDRI AW6 E AW8

For fixing accessories mounting on triple piston rods end-cap, please contact our technical sales department.
The accessories can be mounting on profiled tube or rear end-cap used standard fixing, see pp. **A-22 ÷ A-26.**

Per i fissaggi da applicare alla testata a triplo stelo si prega di consultare il nostro ufficio tecnico-commerciale.
I fissaggi che possono essere montati sulla camicia o sulla testata posteriore sono fissaggi standard specificati a pp. **A-22 ÷ A-26.**

TRANSVERSE FORCE AND TORQUE GRAPHS AW6 AND AW8 SERIES CYLINDERS
DIAGRAMMI FLESSIONE E MOMENTO TORCENTE CILINDRI SERIE AW6 E AW8

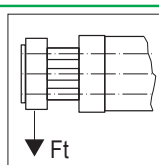
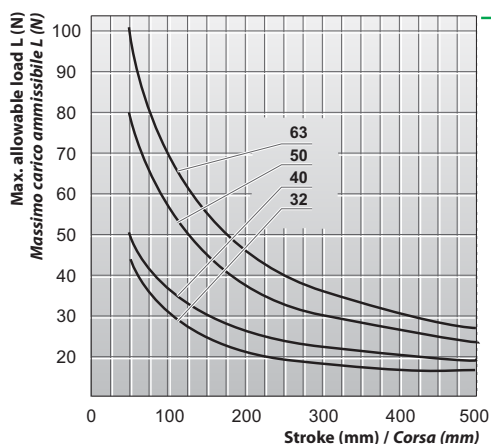

Transverse force
 Flessione

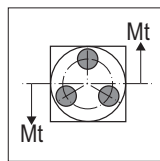

Torque moment
 Momento torcente

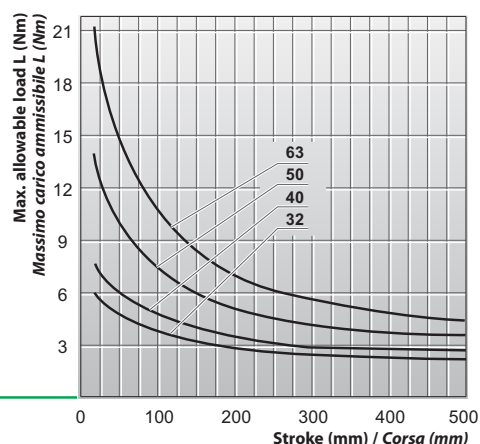

SEALS KIT
 KIT GUARNIZIONI DI RICAMBIO - SG

Seals kit code = **Antirotation cylinder code + Bore + - SG:**
 (The kit includes all seals).

Codice del kit = **Codice del cilindro antirotazione + Alesaggio + - SG:**
 (Il kit comprende tutte le guarnizioni necessarie).

Example / Esempio: **AW8 50 - SG**

