

EAL 58 B / C - 63 A / D / E ANALOGUE SOLID SHAFT SINGLETURN ABSOLUTE ENCODER

MAIN FEATURES

Industry standard singleturn absolute encoder for factory automation applications.

- Optical sensor technology (OptoASIC)
- Programmable measuring range via teach-in function (external inputs or cover button)
- Power supply up to +30 VDC with analogue (voltage or current) electrical interface
- Cable or M12 connector output
- Solid shaft diameter up to 10 mm
- Mounting by synchronous, clamping or centering 2,5" square flange



ORDERING CODE	EAL	63A	16B	12/30	V	05	X	10	X	M12	R	.162	+XXX
SERIES analogue singleturn absolute encoder EAL													
MODEL synchronous flange ø 31.75 mm 63A synchronous flange ø 50 mm 58B clamping flange ø 36 mm 58C centering square flange ø 31.75 mm 63D centering square flange ø 50 mm 63E													
OUTPUT DAC RESOLUTION 16 bit 16B													
POWER SUPPLY 12 ... 30 V DC 12/30													
ELECTRICAL INTERFACE voltage V current I													
OUTPUT RANGE 0 ... 5 V 05 0 ... 10 V 010 0 ... 20 mA 020 4 ... 20 mA 420													
OPTIONS to be reported with voltage output / 3 wires current output X 4 wires current output Q													
SHAFT DIAMETER (mod. 58 B) mm 6 (mod. 63 A / D) 3/8" - mm 9,52 (mod. 58 C - 63 A / D / E) mm 10													
ENCLOSURE RATING IP 65 shaft side / IP67 cover side X IP 67 S													
OUTPUT TYPE cable (standard length 1,5 m) P preferred cable lengths 2 / 3 / 5 / 10 m, to be added after DIRECTION TYPE (eg. PR5) M12 male connector M12													
DIRECTION TYPE radial R													
MATING CONNECTOR mating connector not included .162 to be reported only with connector output (eg. M12R.162), for mating connector see Accessories													
VARIANT custom version XXX													

63 A

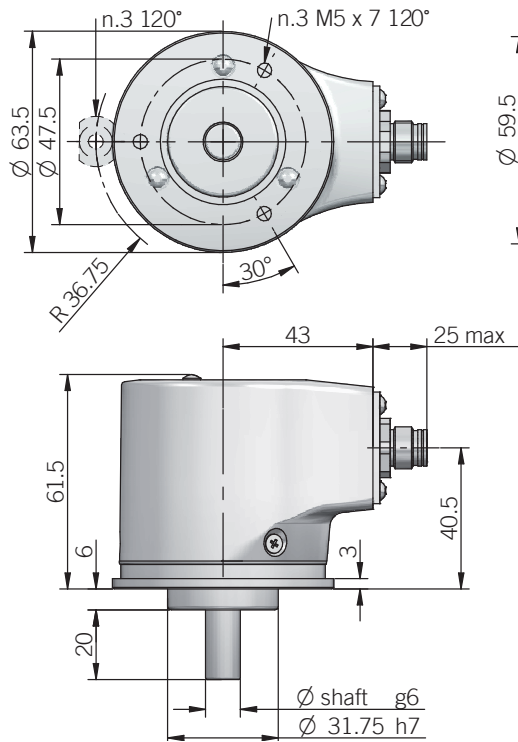

for fixing clamps please refer to Accessories

58 B

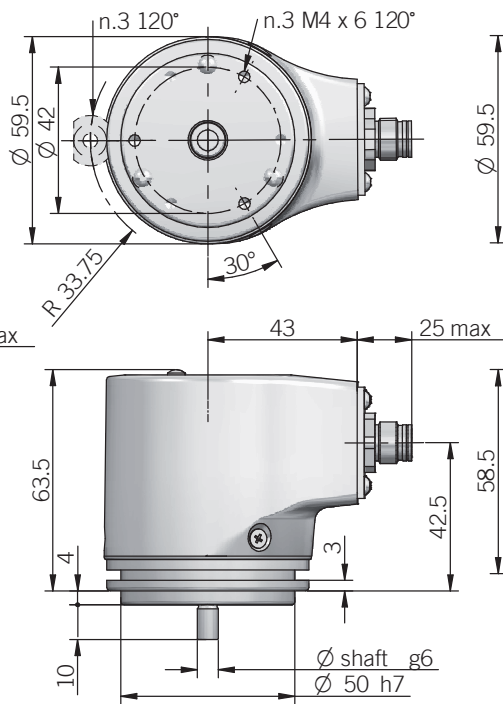

for fixing clamps please refer to Accessories

58 C

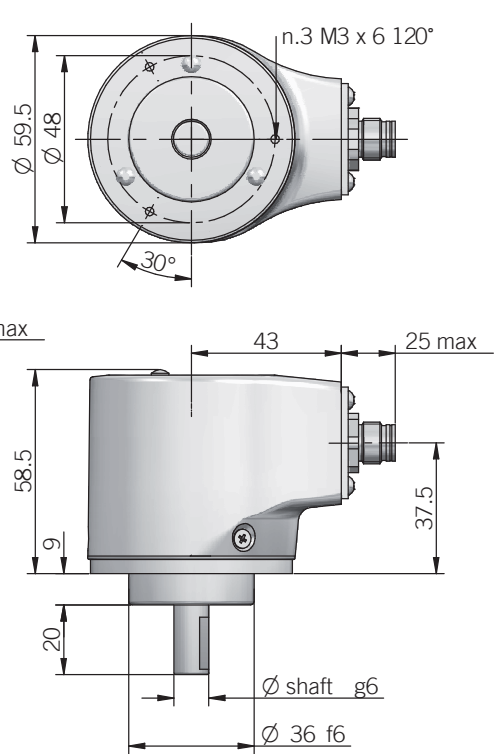

63 D

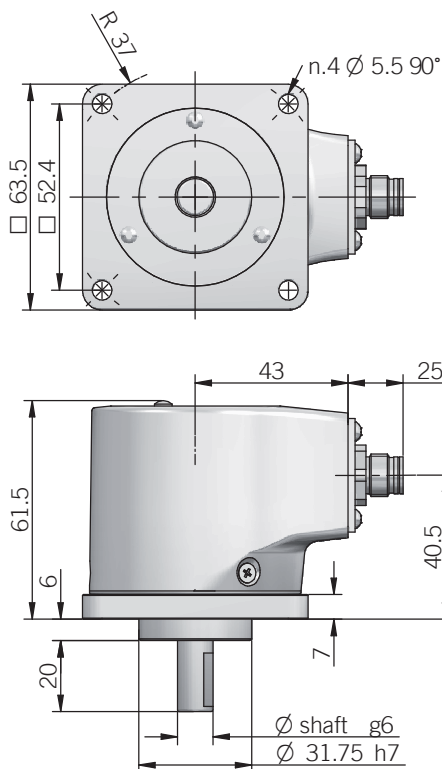

recommended mating shaft tolerance H7
dimensions in mm

63 E

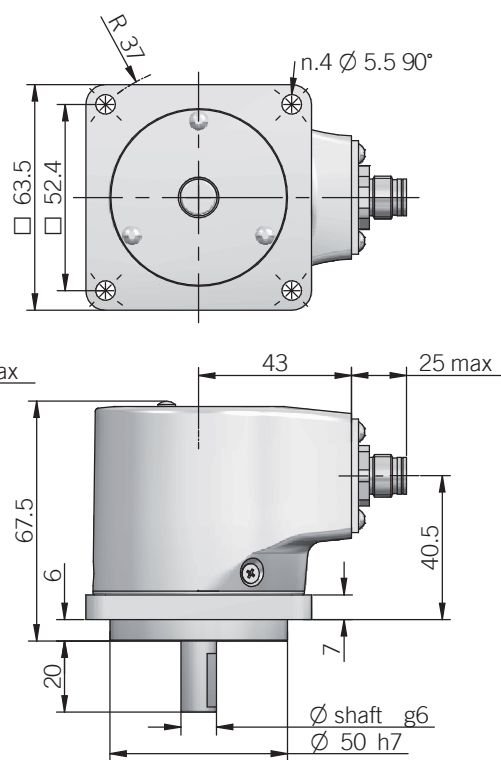

ELECTRICAL SPECIFICATIONS	
Resolution	16 bit
Output DAC resolution	16 bit
Minimum angle	22,5°
Power supply ¹	11,4 ... 30 V DC (reverse polarity protection)
Power draw without load	< 1 W
Electrical interface ²	voltage (0 ... 5 V / 0 ... 10 V) current (0 ... 20 mA / 4 ... 20 mA)
Auxiliary inputs (BEGIN - END)	active high (+V DC) connect to 0 V if not used / t_{min} 150 ms
Load	$R_{min} = 1 \text{ k}\Omega$ (voltage output) $R_{max} = (V \text{ DC} - 2) / 0,02$ (current output)
Output update frequency	16 kHz
Signal pattern	auto teaching according to commissioning
Start-up time	700 ms
Linearity error	± 250 arc-sec
Electromagnetic compatibility	according to 2014/30/EU directive
RoHS	according to 2011/65/EU directive
UL / CSA	certificate n. E212495

MECHANICAL SPECIFICATIONS	
Shaft diameter	$\varnothing 6 / 9,52$ (3/8") / 10 mm
Enclosure rating IEC 60529	X = IP 65 shaft side / IP67 cover side S = IP 67
Max rotation speed	see below table
Max shaft load ³	200 N axial / 70 N radial
Shock	50 G, 11 ms (IEC 60068-2-27)
Vibration	10 G, 10 ... 2000 Hz (IEC 60068-2-6)
Moment of inertia	$1,5 \times 10^{-6} \text{ kgm}^2$ ($36 \times 10^{-6} \text{ lbf}\cdot\text{ft}^2$)
Starting torque (at +20°C / +68°F)	< 0,03 Nm (4,25 Ozin)
Bearing stage material	EN-AW 2011 aluminum
Shaft material	1.4305 / AISI 303 stainless steel
Housing material	painted aluminium
Bearings	n.2 ball bearings
Bearings life	10^9 revolutions
Operating temperature ^{4,5}	-20° ... +85°C (-4° ... +185°F)
Storage temperature ⁵	-20° ... +85°C (-4° ... +185°F)
Weight	approx 350 g (12,35 oz)

¹ as measured at the transducer without cable influences
² for further details refer to OUTPUT LEVELS on TECHNICAL BASICS section
³ maximum load for static usage
⁴ measured on the transducer flange
⁵ condensation not allowed

ELECTRICAL INTERFACE

Voltage output

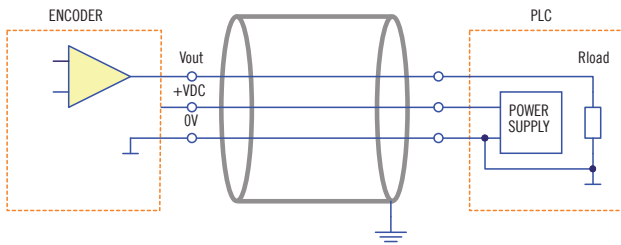

Current output

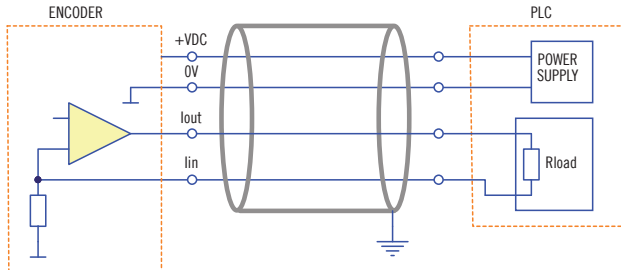

3 / 4 wire source
with 3 wires interface i_{in} is internally connected to 0V

ROTATION SPEED / TEMPERATURE TABLE

Temperature °C (°F)	Max speed (rpm)	Max continuous speed (rpm)
up to +70 (+158)	10000	8000
+70 ... +85 (+158 ... +185)	8000	5000

CONNECTIONS

Function	Cable	5 pin M12	8 pin M12*
+ V DC	red	2	2
0 V	black	3	3
V _{out} / I _{out}	green	1	1
I _{in}	yellow	/	6
BEGIN	white	4	4
END	brown or grey	5	5
⊥	shield	housing	housing

* with Q current output

M12 connector (5 pin)
M12 A coded
solder side view FV

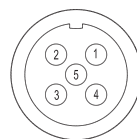

M12 connector (8 pin)
M12 A coded
solder side view FV

