

### MAIN FEATURES

Industry standard singleturn absolute encoder for factory automation applications.

- Optical sensor technology (OptoASIC)
- Programmable measuring range via teach-in function (external inputs or cover button)
- Power supply up to +30 VDC with analogue (voltage or current) electrical interface
- Cable or M12 connector output
- Blind hollow shaft up to 15 mm
- Mounting by stator coupling, torque stop slot or torque pin



ORDERING CODE	EAL	58F	16B	12/30	V	05	X	15	X	M12	R	.162	+XXX
<b>SERIES</b> analogue singleturn absolute encoder	EAL												
<b>MODEL</b> blind hollow shaft with stator coupling blind hollow shaft with torque stop slot blind hollow shaft with torque pin		58F 63F 63G											
<b>OUTPUT DAC RESOLUTION</b> 16 bit		16B											
<b>POWER SUPPLY</b> 12 ... 30 V DC		12/30											
<b>ELECTRICAL INTERFACE</b> voltage current		V I											
<b>OUTPUT RANGE</b> 0 ... 5 V 0 ... 10 V 0 ... 20 mA 4 ... 20 mA		05 010 020 420											
<b>OPTIONS</b> to be reported with voltage output / 3 wires current output 4 wires current output		X Q											
<b>BORE DIAMETER</b> mm mm diameters 6 / 8 / 9,52 (3/8") / 10 / 11 / 12 mm with optional shaft adapter, see Accessories		14 15											
<b>ENCLOSURE RATING</b> IP 65 shaft side / IP67 cover side IP 67		X S											
<b>OUTPUT TYPE</b> cable (standard length 1,5 m) preferred cable lengths 2 / 3 / 5 / 10 m, to be added after DIRECTION TYPE (eg. PR5) M12 male connector		P M12											
<b>DIRECTION TYPE</b> radial		R											
<b>MATING CONNECTOR</b> mating connector not included to be reported only with connector output (eg. M12R.162), for mating connector see Accessories		.162											
<b>VARIANT</b> custom version		XXX											

58 F

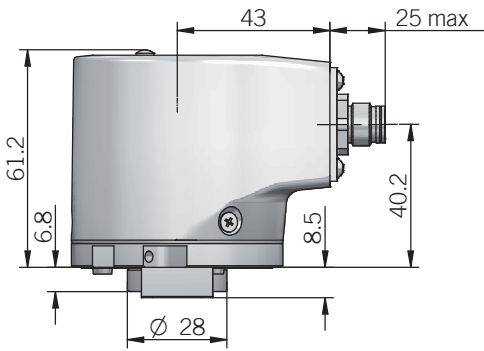
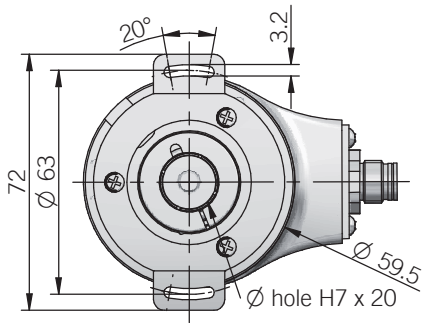

63 F

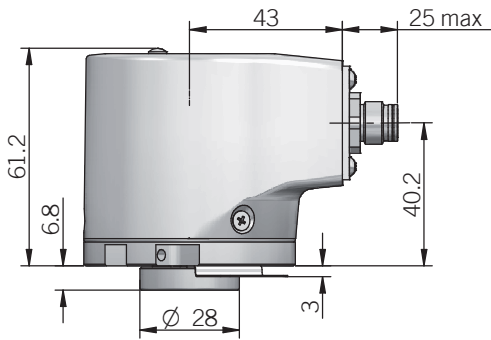
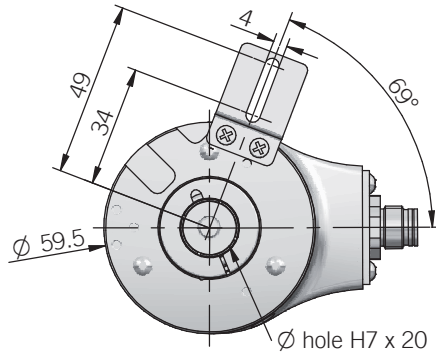

for torque pin please refer to Accessories

63 G

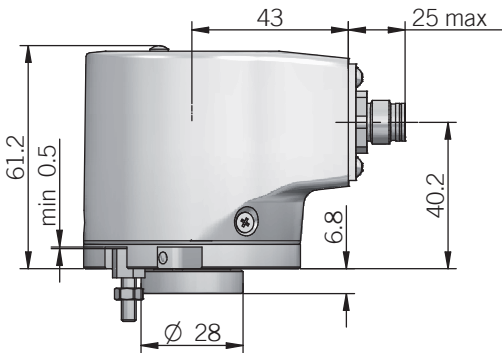
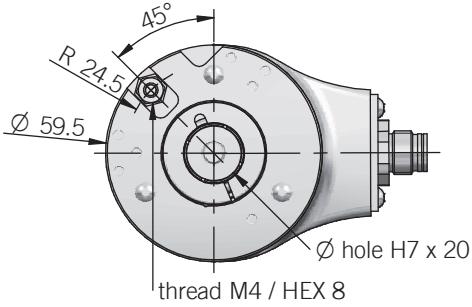

torque pin is included  
recommended mating shaft tolerance g6  
dimensions in mm

ELECTRICAL SPECIFICATIONS	
Resolution	16 bit
Output DAC resolution	16 bit
Minimum angle	22,5°
Power supply <sup>1</sup>	11,4 ... 30 V DC (reverse polarity protection)
Power draw without load	< 1 W
Electrical interface <sup>2</sup>	voltage (0 ... 5 V / 0 ... 10 V) current (0 ... 20 mA / 4 ... 20 mA)
Auxiliary inputs (BEGIN - END - U/D)	active high (+V DC) connect to 0 V if not used / $t_{min}$ 150 ms
Load	$R_{min} = 1 \text{ k}\Omega$ (voltage output) $R_{max} = (V \text{ DC} - 2) / 0,02$ (current output)
Output update frequency	16 kHz
Signal pattern	auto teaching according to commissioning
Start-up time	700 ms
Linearity error	$\pm 250$ arc-sec
Electromagnetic compatibility	according to 2014/30/EU directive
RoHS	according to 2011/65/EU directive
UL / CSA	certificate n. E212495

MECHANICAL SPECIFICATIONS	
Bore diameter	$\phi 14 / 15 \text{ mm}$ $\phi 6^* / 8^* / 9,52 (3/8)^* / 10^* / 11^* / 12^* \text{ mm}$ * with optional shaft adapter, please refer to Accessories
Enclosure rating IEC 60529	X = IP 65 shaft side / IP67 cover side S = IP 67
Max rotation speed	see table
Max shaft load <sup>3</sup>	200 N axial / 60 N radial
Shock	50 G, 11 ms (IEC 60068-2-27)
Vibration	10 G, 10 ... 2000 Hz (IEC 60068-2-6)
Moment of inertia	$5 \times 10^{-6} \text{ kgm}^2$ ( $119 \times 10^{-6} \text{ lbft}^2$ )
Starting torque (at +20°C / +68°F)	< 0,03 Nm (4,25 Ozin)
Bearing stage material	EN-AW 2011 aluminum
Shaft material	1.4305 / AISI 303 stainless steel
Housing material	painted aluminium
Bearings	n.2 ball bearings
Bearings life	$10^9$ revolutions
Operating temperature <sup>4,5</sup>	-20° ... +85°C (-4° ... +185°F)
Storage temperature <sup>5</sup>	-20° ... +85°C (-4° ... +185°F)
Weight	approx 350 g (12,35 oz)

<sup>1</sup> as measured at the transducer without cable influences

<sup>2</sup> for further details refer to OUTPUT LEVELS on TECHNICAL BASICS section

<sup>3</sup> maximum load for static usage

<sup>4</sup> measured on the transducer flange

<sup>5</sup> condensation not allowed

### ELECTRICAL INTERFACE

#### Voltage output

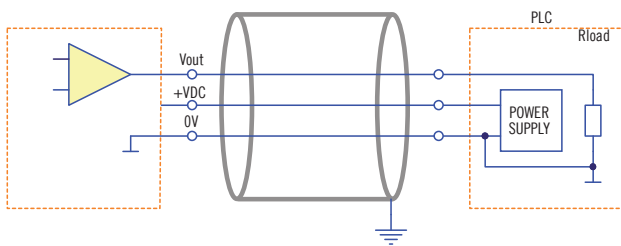

#### Current output

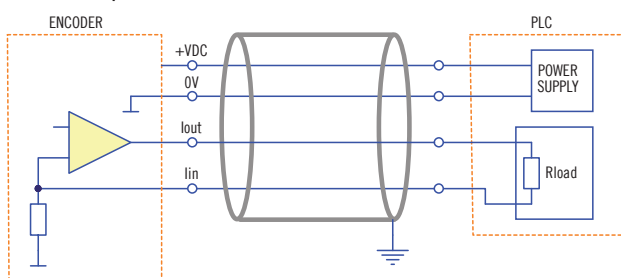

3 / 4 wire source with 3 wires interface I<sub>in</sub> is internally connected to 0V

### ROTATION SPEED / TEMPERATURE TABLE

	Temperature °C (°F)	Max speed (rpm)	Max continuous speed (rpm)
IP65	up to +70 (+158)	9000	6000
	+70 ... +85 (+158 ... +185)	6000	3000
IP67	up to +70 (+158)	8000	4000
	+70 ... +85 (+158 ... +185)	4000	2000

### CONNECTIONS

Function	Cable	5 pin M12	8 pin M12*
+ V DC	red	2	2
0 V	black	3	3
V <sub>out</sub> / I <sub>out</sub>	green	1	1
I <sub>in</sub>	yellow	/	6
BEGIN	white	4	4
END	brown or grey	5	5
≡	shield	housing	housing

\* with Q current output

M12 connector (5 pin)  
M12 A coded  
solder side view FV

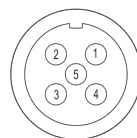

M12 connector (8 pin)  
M12 A coded  
solder side view FV

