

MAIN FEATURES

Series of miniaturized encoders for integration on small size AC/DC motors, stepper motors or for limited size applications.

- 3 channel encoder (A / B / Z) up to 1024 ppr
- Power supply up to +30 V DC with several electrical interfaces available
- Up to 105 kHz output frequency
- No wear due to absense of bearings
- Easy assembly
- Compact size



ORDERING CODE	EH	30M	500	S	5/30	P	6	X	6	PR	.XXX
SERIES incremental encoder series EH											
MODEL kit encoder with flange 17M kit encoder 30M											
RESOLUTION ppr from 50 to 1024 refer to the available pulses list											
ZERO PULSE without zero pulse S with zero pulse Z											
POWER SUPPLY 5 V DC 5 5 ... 30 V DC 5/30											
ELECTRICAL INTERFACE NPN open collector C push-pull P line driver L power supply 5/30V - output RS-422 RS											
BORE DIAMETER mm 6 (1/4") mm 6,35											
ENCLOSURE RATING (mod. 17M) IP40 - (mod. 30M) IP 54 X											
MAX ROTATION SPEED 6000 rpm 6											
OUTPUT TYPE radial cable (standard length 0,5 m) PR preferred cable lengths 1,5 / 2 / 3 / 5 / 10 m, to be added after OUTPUT TYPE (eg. PR5)											
VARIANT custom version XXX											

17 M

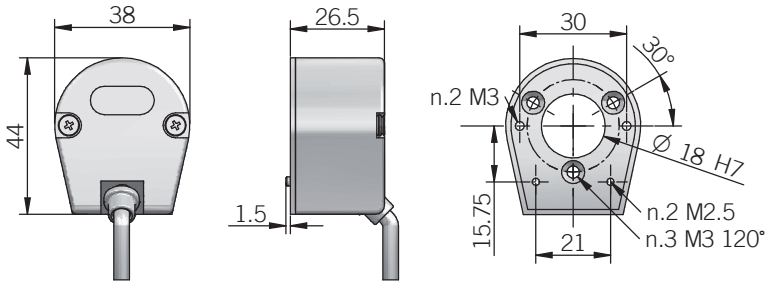

30 M

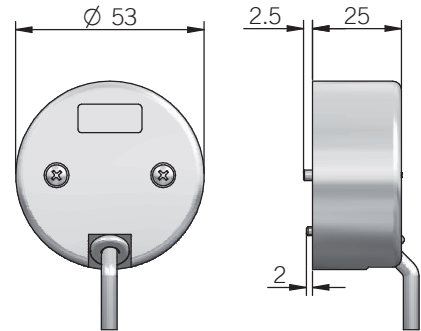

RECOMMENDED INTERFACE FLANGE DESIGN

17 M

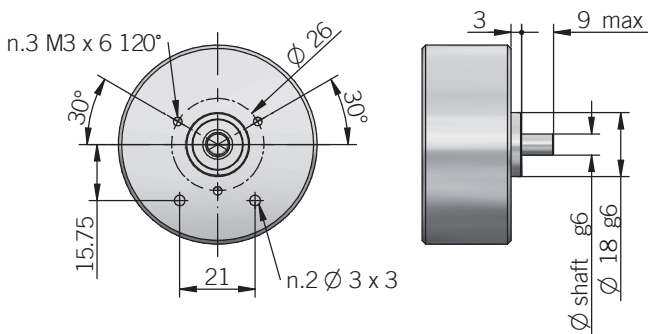

30 M

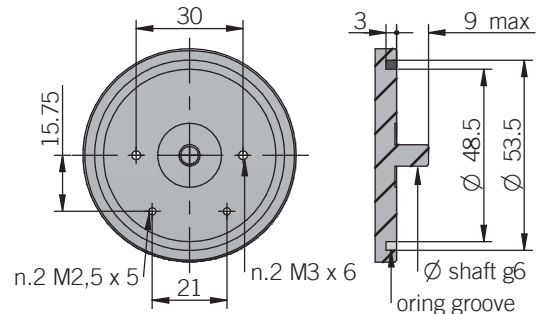

dimensions in mm

ELECTRICAL SPECIFICATIONS	
Resolution	from 50 to 1024 ppr
Power supply¹	5 = 4,5 ... 5,5 V DC 5/30 = 4,5 ... 30 V DC (reverse polarity protection)
Current consumption without load	50 mA (2 channels A / B) 100 mA (3 channels A / B / Z)
Max load current	C / P = 50 mA / channel L = 20 mA / channel
Electrical interface²	NPN open collector (AEIC-7273, pull-up max +30 V DC) push-pull / line driver HTL (AEIC-7272) line driver RS-422 (AELT-5000 or similar)
Max output frequency	105 kHz
Counting direction	A leads B clockwise (shaft view)
Electromagnetic compatibility	according to 2014/30/EU directive
RoHS	according to 2011/65/EU directive
UL / CSA	certificate n. E212495

CONNECTIONS		
Function	Cable P	Cable L / RS
+V DC	red	red
0 V	black	black
A+	green	green
A-	/	brown or grey
B+	yellow	yellow
B-	/	orange
Z+	blue	blue
Z-	/	white
≡	shield	shield

MECHANICAL SPECIFICATIONS	
Bore diameter	Ø 6 / 6,35 (1/4") mm
Enclosure rating	mod. 17 IP 40 (IEC 60529) mod. 30 IP 54 (IEC 60529) when properly installed with oring kit (not supplied, please refer to the Accessories)
Max rotation speed	6000 rpm (limited by output frequency)
Shock	50 G, 11 ms (IEC 60068-2-27)
Vibration	10 G, 10 ... 2000 Hz (IEC 60068-2-6)
Moment of inertia	0,5 x 10 ⁻⁶ kgm ² (12 x 10 ⁻⁶ lbf ²)
Flange material (mod. 17)	aluminium
Hub material	EN-AW 2011 aluminium
Cover material	PA66 glass fiber reinforced
Shaft radial play allowed	± 0,04 mm
Shaft axial play allowed	± 0,1 mm
Operating temperature^{3,4}	-20° ... +60°C (-4° ... +140°F)
Storage temperature⁴	-25° ... +70°C (-13° ... +158°F)
Weight	50 g (1,76 oz)

¹ as measured at the transducer without cable influences
² for further details refer to OUTPUT LEVELS on TECHNICAL BASICS section
³ measured on the transducer flange
⁴ condensation not allowed

RESOLUTIONS
50* - 100 - 200 - 256 - 360 - 400 - 500 - 512 - 1000 - 1024

*available only without zero pulse
 please directly contact our offices for other pulses, preferred resolutions in bold