

MAIN FEATURES

Series of miniaturized encoders with innovative proprietary magnetic sensor for integration on small size AC/DC motors, stepper motors or for limited size applications.

- 3 channel encoder (A / B / Z) with resolution up to 10000 ppr
- Power supply up to +30 V DC with several electrical interfaces available
- Cable output, connectors available on cable end
- Compact dimensions (height < 25 mm)
- No wear due to non contact magnetic technology
- Bore shaft diameter up to 10 mm
- Wide operating temperature -20° ... +100°C (-4° ... +212°F)
- OEM version without cover available



ORDERING CODE	EMI	30M	*S	50	Z	5/30	P	6	X	X	PR	.XXX
SERIES magnetic incremental encoder series EMI												
MODEL kit encoder 30M												
COVER * add if without cover S												
RESOLUTION ppr from 1 to 10000 please refer to the preferred resolutions list												
ZERO PULSE without zero pulse S with zero pulse Z												
POWER SUPPLY 5 V DC 5 5 ... 30 V DC 5/30												
ELECTRICAL INTERFACE NPN open collector C push-pull P line driver L power supply 5/30 V DC - output RS-422 RS												
BORE DIAMETER mm 6 (1/4") mm 6,35 mm 8 mm 10												
ENCLOSURE RATING IP 54 X												
OPTION to be reported X												
OUTPUT TYPE radial cable (standard length 0,5 m) PR preferred cable lengths 1,5 / 2 / 3 / 5 / 10 m, to be added after OUTPUT TYPE (eg. PR5)												
VARIANT custom version XXX												

30 M

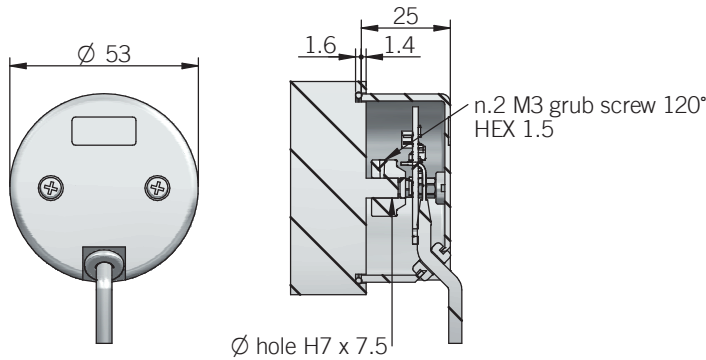

RECOMMENDED INTERFACE FLANGE DESIGN

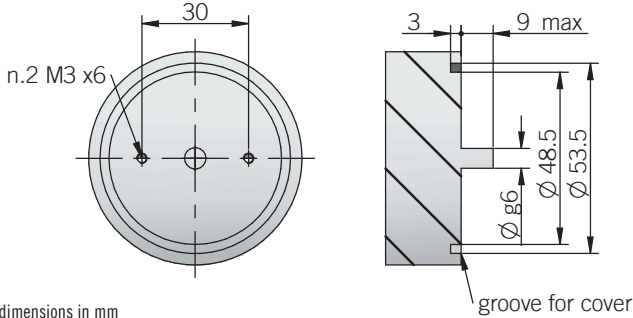

dimensions in mm

MAGNET-ACTUATOR INSTALLATION

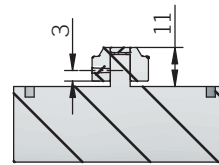

ELECTRICAL SPECIFICATIONS	
Resolution	from 1 to 10000 ppr
Power supply¹	5 = 4,5 ... 5,5 V DC 5/30 = 4,5 ... 30 V DC (reverse polarity protection)
Power draw without load typical	0,4 W
Max load current	C / P = 50 mA / channel L / RS = 20 mA / channel
Electrical interface²	NPN open collector (AEIC-7273, pull-up max +30 V DC) push-pull / line driver HTL (AEIC-7272 or similar) line driver RS-422 (AELT-5000 or similar)
Max output frequency	800 kHz
Counting direction	A leads B clockwise (shaft view)
Index signal	180°e (&A)
Startup time typical	10 ms
Accuracy	< 0,3° at +20°C (+68°F) ± 0,5° in the operating temperature range
Hysteresis	0,70° up to 256 ppr 0,35° from 257 ppr to 10000 ppr
Electromagnetic compatibility	according to 2014/30/EU directive
RoHs	according to 2011/65/EU directive
UL / CSA	file n. E212495

PREFERRED RESOLUTIONS
2 - 4 - 5 - 6 - 8 - 10 - 12 - 16 - 20 - 30 - 40 - 50 - 60 - 80 - 90 - 100 - 125 - 128 - 200 - 250 - 256 - 360 - 400 - 500 - 512 - 720 - 1000 - 1024 - 1440 - 2000 - 2048 - 3600 - 4096 - 5000 - 7200 - 10000

please directly contact our offices for other pulses

MECHANICAL SPECIFICATIONS	
Bore diameter	∅ 6 / 6,35 (1/4") / 8 / 10 mm
Enclosure rating	IP 54 (IEC 60529) when properly installed with supplied oring kit
Max rotation speed	limited only by output frequency
Shock	50 G, 11 ms (IEC 60068-2-27)
Vibration	20 G, 10 ... 2000 Hz (IEC 60068-2-6)
Moment of inertia	0,1 x 10 ⁻⁶ kgm ² (2,4 x 10 ⁻⁶ lbf ²)
Magnet-actuator material	EN-AW 2011 / 2033 aluminium
Cover material	PA66 glass fiber reinforced
Shaft radial play allowed	± 0,25 mm
Shaft axial play allowed	± 0,5 mm
Operating temperature^{3,4}	-20° ... +100°C (-4° ... +212°F)
Storage temperature⁴	-20° ... +100°C (-4° ... +212°F)
Weight	100 g approx (3,5 oz)

¹ as measured at the transducer without cable influences

² for further details refer to OUTPUT LEVELS on TECHNICAL BASICS section

³ measured on the transducer flange

⁴ condensation not allowed

CONNECTIONS		
Function	Cable C / P	Cable L / RS
+V DC	red	red
0 V	black	black
A+	green	green
A-	/	brown or grey
B+	yellow	yellow
B-	/	orange
Z+	blue	blue
Z-	/	white
≡	shield	shield