

## Shock Absorbers for Side Forces



800.909.4988  
info@rankinusa.com

# Shock Absorbers for Side Forces

## WSB-M / WPB-M / WEB-M



### FEATURES

Designed for side forces up to 15° without additional mounting parts

Material.....	Housing: ProSurf
Extended Life Time .....	Special Seals + Oils
.....	Piston rod: hardened, stainless steel
Temperature: .....	-20°C - +80°C / option: -50°C - +120°C ( -4°F- +176°F / option: -58°F - +248°F)
Integrated End Stop .....	Full Stroke Operation
RoHS - conform .....	Directive 2002/95/EC
Special models available from stock .....	Stainless steel (Page 62,63)
.....	for pressure chambers up to 7 bar
.....	USDA-H1-compliant for food industry
Included .....	1 Stop cap (steel), 1 Lock nut

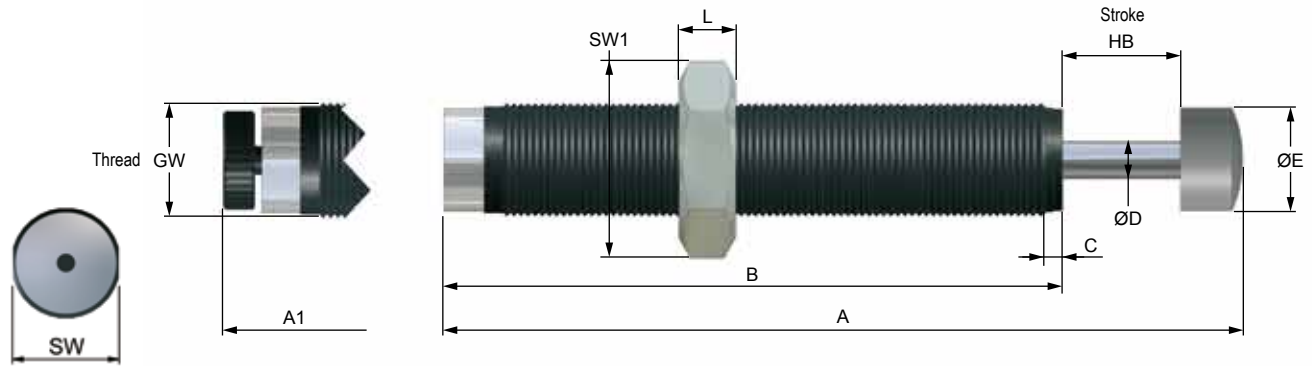

## DIMENSIONS

			Thread	A	A1	B	C	D	E	L	SW	SW1
				mm (inch)	mm (inch)	mm (inch)	mm (inch)	mm (inch)	mm (inch)	mm (inch)	mm (inch)	mm (inch)
WSB-M 0,15-1/2/3/4	WPB-M 0,15-1/2/3	WEB-M 0,15	M 10 x 1,0	66 (2.6)	68,5 (2.7)	49,5 (1.95)	2,5 (0.1)	3 (0.12)	8,5 (0.33)	3 (0.12)	-	13 (0.51)
WSB-M 0,2-1/2/3/4	WPB-M 0,2-1/2/3	WEB-M 0,2	M 12 x 1,0	85 (3.35)	89,5 (3.52)	66 (2.6)	2,5 (0.1)	4 (0.16)	10 (0.39)	4 (0.16)	-	14 (0.55)
WSB-M 0,25-0/1/2/3/4	WPB-M 0,25-1/2/3	WEB-M 0,25	M 14 x 1,0	100 (3.94)	105 (4.13)	78 (3.07)	2,5 (0.1)	4 (0.16)	10 (0.39)	5 (0.2)	13 (0.51)	17 (0.67)
WSB-M 0,5x19 -0/1/2/3/4	WPB-M 0,5x19 -1/2/3	WEB-M 0,5 x 19	M 20 x 1,0	117 (4.61)	123 (4.84)	88 (3.46)	2,5 (0.1)	6 (0.24)	16 (0.63)	6 (0.24)	18 (0.71)	24 (0.94)
WSB-M 1,0-0/1/2/3/4	WPB-M 1,0-1/2/3	WEB-M 1,0	M 24 x 1,5	146 (5.75)	154 (6.06)	108 (4.25)	3,5 (0.14)	8 (0.31)	20 (0.79)	8 (0.31)	23 (0.91)	30 (1.18)

## PERFORMANCE

	Stroke mm (inch)	Energy absorption Nm/HB (max.) (lbs/HB (max.)) Nm/h (max.) (lbs/h (max.))		Effective mass										Return spring force min. N (min. N) max. N (max. N)		Torque Nm max. (lbs max.)	Weight g (lbs)
				-0 (very soft)		-1 (soft)		-2 (medium)		-3 (hard)		-4 (very hard)					
				min kg (min lbs)	max kg (max lbs)	min kg (min lbs)	max kg (max lbs)	min kg (min lbs)	max kg (max lbs)	min kg (min lbs)	max kg (max lbs)	min kg (min lbs)	max kg (max lbs)				
WSB-M 0,15	8 (0.31)	12 (106)	24000 (212000)	-	-	1,6 (3.5)	7,5 (16.5)	6,1 (13.4)	71 (156)	61 (134)	252 (555)	232 (511)	750 (1653)	3,6 (0.8)	8 (1.8)	6 (53)	0,02 (0.04)
WSB-M 0,2	10 (0.39)	18 (160)	36000 (320000)	-	-	2 (4.4)	11 (24.3)	10 (22)	107 (236)	104 (229)	360 (793)	343 (756)	1100 (2425)	3,5 (0.79)	7 (1.57)	10 (88)	0,036 (0.08)
WSB-M 0,25	14 (0.55)	24 (212)	52800 (468000)	0,9 (2)	8 (17.6)	3,5 (7.7)	17 (37.5)	9,9 (99)	76 (167)	62 (136)	252 (555)	250 (551)	1550 (3417)	13 (2.92)	23 (5.17)	20 (177)	0,05 (0.11)
WSB-M 0,5x19	19 (0.75)	80 (710)	76800 (680000)	2,6 (5.7)	10,6 (23.3)	10 (22.1)	86 (189.6)	40 (21.8)	209 (460)	170 (374)	800 (1765)	680 (1500)	4050 (8928)	12 (2.7)	23 (5.17)	25 (221)	0,13 (0.29)
WSB-M 1,0	25 (0.98)	180 (1593)	108000 (960000)	6 (13.2)	29 (70)	24 (53)	120 (264.5)	70 (154.3)	460 (1014)	440 (970)	2050 (4520)	1760 (3880)	10800 (23810)	15 (3.37)	31 (7)	30 (265)	0,25 (0.55)
WPB-M 0,15	8 (0.31)	12 (106)	24000 (212000)	-	-	1 (2.2)	2,2 (4.8)	2 (4.4)	7,5 (16.5)	6,1 (13.4)	71 (156)	-	-	3,6 (0.8)	8 (1.8)	6 (53)	0,02 (0.04)
WPB-M 0,2	10 (0.39)	18 (160)	36000 (320000)	-	-	1,5 (3.3)	2,8 (6.2)	2 (4.4)	21 (46.3)	17 (37.5)	92 (202)	-	-	3,5 (0.79)	7 (1.57)	10 (88)	0,036 (0.08)
WPB-M 0,25	14 (0.55)	24 (212)	52800 (468000)	-	-	0,9 (2)	2,4 (5.3)	2,3 (5.1)	26 (57.3)	21 (46.3)	165 (363)	-	-	13 (2.92)	23 (5.17)	20 (177)	0,05 (0.11)
WPB-M 0,5x19	19 (0.75)	80 (710)	76800 (680000)	-	-	2,6 (5.7)	12,5 (27.6)	10 (22)	89 (196)	69 (152)	555 (1225)	-	-	12 (2.7)	23 (5.17)	25 (221)	0,13 (0.29)
WPB-M 1,0	25 (0.98)	180 (1593)	108000 (960000)	-	-	6 (13.2)	27,5 (60.6)	21 (46.3)	195 (430)	150 (330)	1200 (2645)	-	-	15 (3.37)	31 (7)	30 (265)	0,25 (0.55)
WEB-M 0,15	8 (0.31)	12 (106)	24000 (212000)	-	-	1 (2.2)	500 (1100)	-	-	-	-	-	-	3,6 (0.8)	8 (1.8)	6 (53)	0,02 (0.04)
WEB-M 0,2	10 (0.39)	18 (160)	36000 (320000)	-	-	9 (19.9)	800 (1700)	-	-	-	-	-	-	3,5 (0.79)	7 (1.57)	10 (88)	0,036 (0.08)
WEB-M 0,25	14 (0.55)	24 (212)	52800 (468000)	-	-	1,6 (3.5)	1600 (3530)	-	-	-	-	-	-	13 (2.92)	23 (5.17)	20 (177)	0,055 (0.12)
WEB-M 0,5x19	19 (0.75)	80 (710)	76800 (680000)	-	-	9 (19.9)	4500 (9920)	-	-	-	-	-	-	12 (2.7)	23 (5.17)	25 (221)	0,14 (0.31)
WEB-M 1,0	25 (0.98)	180 (1593)	108000 (960000)	-	-	22 (48.5)	11000 (24250)	-	-	-	-	-	-	15 (3.37)	31 (7)	30 (265)	0,29 (0.64)