

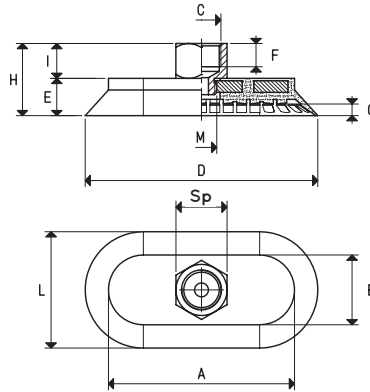

FLAT AND BELLOWS ELLIPTICAL VACUUM CUPS

3D drawings are available on vuotecnica.net

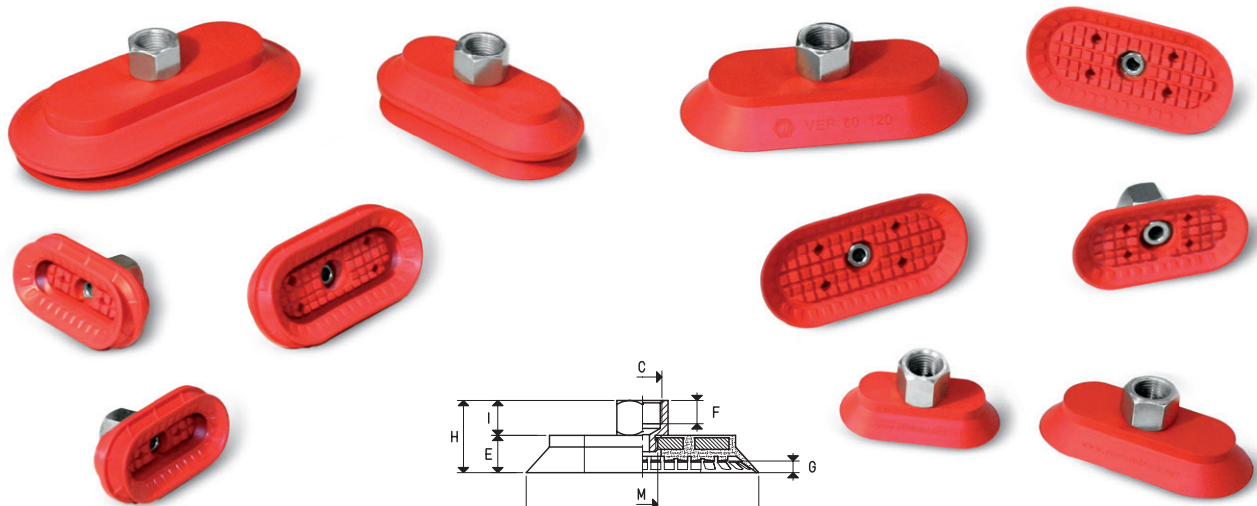

ELLIPTICAL VACUUM CUPS WITH VULCANISED SUPPORT

Item	Force Kg	Volume cm ³	A	B	C Ø	Sp	D	E	F	G	H	I	L	M Ø	Support material	Weight g
VEP 30 60 *	4.01	4.5	47	17	G1/4"	17	60	13	10	3	27	14	30	G1/8"	steel	42.6
VEP 30 90 *	6.26	7.0	77	17	G1/4"	17	90	13	10	3	27	14	30	G1/8"	steel	63.5
VEP 40 80 *	7.14	13.2	70	30	G1/4"	17	80	14	10	4	28	14	40	G1/8"	steel	68.0
VEP 50 100 *	11.15	15.0	80	30	G3/8"	22	100	16	10	5	31	15	50	G1/4"	steel	110.0
VEP 60 120 *	16.06	32.1	95	35	G3/8"	22	120	18	10	6	33	15	60	G1/4"	steel	156.1
VEP 70 140 *	21.86	53.5	110	40	G3/8"	22	140	19	10	7	34	15	70	G1/4"	steel	199.4

* Complete the code indicating the compound: B= BENZ rubber; N= natural para rubber; S = silicone

Note: Height "C" available with NPT threading. Ordering example: VEP 40 80 NPT B

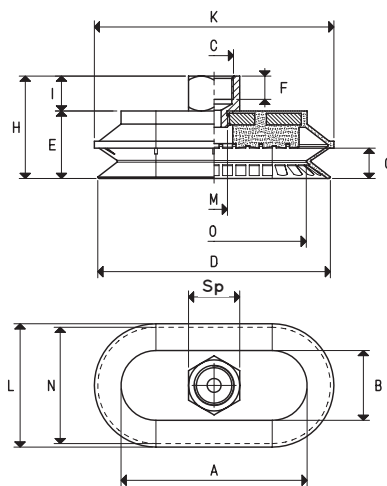

BELLOWS ELLIPTICAL VACUUM CUPS WITH VULCANISED SUPPORT

Item	Force Kg	Volume cm ³	A	B	C Ø	Sp	D	E	F	G	H	K	I	L	M Ø	N	O	Support material	Weight g
VES 30 60 *	4.01	12.6	50	20	G1/4"	17	60	21	10	7.0	35	63	14	33	G1/8"	30	44.5	steel	49.5
VES 40 80 *	7.14	24.8	70	30	G1/4"	17	80	23	10	9.0	37	83	14	43	G1/8"	40	64.0	steel	91.9
VES 50 100 *	11.15	57.6	80	30	G3/8"	22	100	29	10	13.0	44	103	15	53	G1/4"	50	79.0	steel	125.3
VES 70 140 *	21.86	122.8	110	40	G3/8"	22	140	33	10	16.5	48	143	15	73	G1/4"	70	109.0	steel	227.8

* Complete the code indicating the compound: B= BENZ rubber; N= natural para rubber; S = silicone

Note: Height "C" available with NPT threading. Ordering example: VES 40 80 NPT B

Note: The force of the vacuum cups indicated in the table represents 1/3 of the value of the theoretical force calculated at a level of vacuum of -75 KPa and a factor of safety 3.

Transformation ratio: N (newton) = Kg x 9.81 (force of gravity)

inch = $\frac{\text{mm}}{25.4}$; pounds = $\frac{\text{g}}{453.6} = \frac{\text{Kg}}{0.4536}$

Adapters for GAS - NPT threading available on page 1.130