



VACUUM CUPS WITH TWO BELLOWS FOR HEAVY-DUTY PACKAGING

Specifically designed vacuum cups for tripping and handling particularly heavy boxes and cardboard packaging in general.

Their thick, sturdy lip absorbs tears and sudden accelerations, typical of robotised movements. The double bellows enables improved adaptability to the gripping surface, even if not perfectly perpendicular to the axis of the vacuum cup, and can recover evident unevenness of the loads to be lifted.

The supports, all made of anodised aluminium, are equipped with a male or female central threaded pin to allow suctioning and clamping to the automation. The vacuum cups can be fitted on them without the aid of adhesives.

To replace, simply request the single vacuum cup indicated in the table in the desired compound.

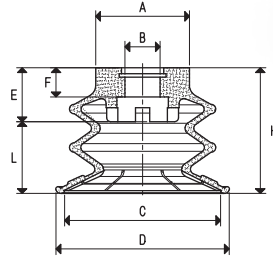

VACUUM CUPS

Item	Force Kg	Volume cm ³	A Ø	B Ø	C Ø	D Ø	E	F	H	L	Bellows stroke mm
01 35 27 *	2.26	7.3	20	7.5	34	37	11.5	6.2	27	15.5	13
01 52 40 *	5.31	25.2	27	11.5	52	55	16.0	8.2	39	23.0	20

* Complete the code indicating the compound: A= oil-resistant rubber; N= natural para rubber; S= silicone

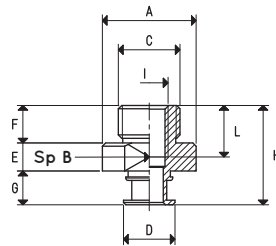

MALE SUPPORTS

Item	A Ø	B	C Ø	D Ø	E	F	G	H	I	L	Support material	For vacuum cup item	Weight g
00 08 394	20	17	G1/8"	11	6.0	8	7.2	21.2	M5	8	aluminium	01 35 27	6.2
00 08 395	27	20	G1/8"	15	7.5	8	9.2	24.7	M5	8	aluminium	01 52 40	13.2
00 08 366	20	17	G1/4"	11	6.0	8	7.2	21.2	M8	11	aluminium	01 35 27	6.2
00 08 364	27	20	G1/4"	15	7.5	8	9.2	24.7	M8	11	aluminium	01 52 40	13.2

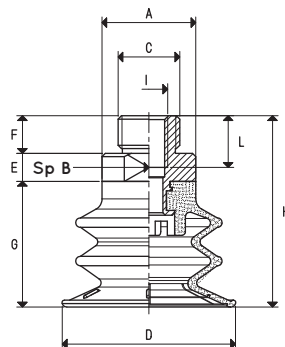

VACUUM CUPS WITH MALE SUPPORT

Item	Force Kg	A Ø	B	C Ø	D Ø	E	F	G	H	I	L	Vacuum cup item	Support item	Weight g
08 35 27 1/8 *	2.26	20	17	G1/8"	37	6.0	8	27	41.0	M5	8	01 35 27	00 08 394	13.0
08 52 40 1/8 *	5.31	27	20	G1/8"	55	7.5	8	39	54.5	M5	8	01 52 40	00 08 395	34.5
08 35 27 *	2.26	20	17	G1/4"	37	6.0	8	27	41.0	M8	11	01 35 27	00 08 366	12.9
08 52 40 *	5.31	27	20	G1/4"	55	7.5	8	39	54.5	M8	11	01 52 40	00 08 364	34.3

* Complete the code indicating the compound: A= oil-resistant rubber; N= natural para rubber; S= silicone

Note: The force of the vacuum cups indicated in the table represents 1/3 of the value of the theoretical force calculated at a level of vacuum of -75 KPa and a factor of safety 3.

Transformation ratio: N (newton) = Kg x 9.81 (force of gravity)

inch = $\frac{\text{mm}}{25.4}$; pounds = $\frac{\text{g}}{453.6} = \frac{\text{Kg}}{0.4536}$

Adapters for GAS - NPT threading available on page 1.130

VACUUM CUPS WITH TWO BELLOWS WITH FEMALE SUPPORTS

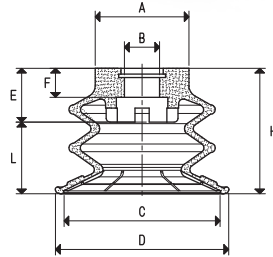

VACUUM CUPS

Item	Force Kg	Volume cm ³	A Ø	B Ø	C Ø	D Ø	E	F	H	L	Bellows stroke mm
01 35 27 *	2.26	7.3	20	7.5	34	37	11.5	6.2	27	15.5	13
01 52 40 *	5.31	25.2	27	11.5	52	55	16.0	8.2	39	23.0	20

* Complete the code indicating the compound: A= oil-resistant rubber; N= natural para rubber; S= silicone

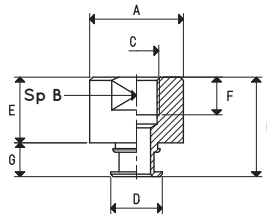

FEMALE SUPPORTS

Item	A Ø	B	C Ø	D Ø	E	F	G	H	Support material	For vacuum cup item	Weight g
00 08 396	20	17	G1/8"	11	14	8	7.2	21.2	aluminium	01 35 27	9.7
00 08 397	27	20	G1/8"	15	14	8	9.2	23.2	aluminium	01 52 40	20.0
00 08 392	20	17	G1/4"	11	14	10	7.2	21.2	aluminium	01 35 27	7.8
00 08 393	27	20	G1/4"	15	14	10	9.2	23.2	aluminium	01 52 40	18.1

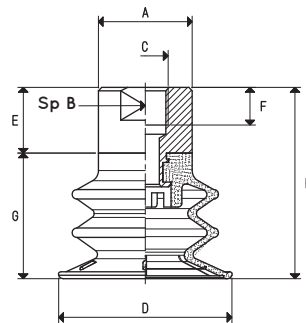

VACUUM CUPS WITH FEMALE SUPPORT

Item	Force Kg	A Ø	B	C Ø	D Ø	E	F	G	H	Vacuum cup item	Support item	Weight g
08 35 27 1/8 F *	2.26	20	17	G1/8"	37	14	8	27	41	01 35 27	00 08 396	16.5
08 52 40 1/8 F *	5.31	27	20	G1/8"	55	14	8	39	53	01 52 40	00 08 397	41.3
08 35 27 F *	2.26	20	17	G1/4"	37	14	10	27	41	01 35 27	00 08 392	14.6
08 52 40 F *	5.31	27	20	G1/4"	55	14	10	39	53	01 52 40	00 08 393	39.4

* Complete the code indicating the compound: A= oil-resistant rubber; N= natural para rubber; S= silicone

Note: The force of the vacuum cups indicated in the table represents 1/3 of the value of the theoretical force calculated at a level of vacuum of -75 KPa and a factor of safety 3.

Transformation ratio: N (newton) = Kg x 9.81 (force of gravity)

$$\text{inch} = \frac{\text{mm}}{25.4}; \text{pounds} = \frac{\text{g}}{453.6} = \frac{\text{Kg}}{0.4536}$$

Adapters for GAS - NPT threading available on page 1.130



VACUUM CUPS WITH TWO BELLOWS WITH MALE SUPPORTS

3D drawings are available on vuototecnica.net

1

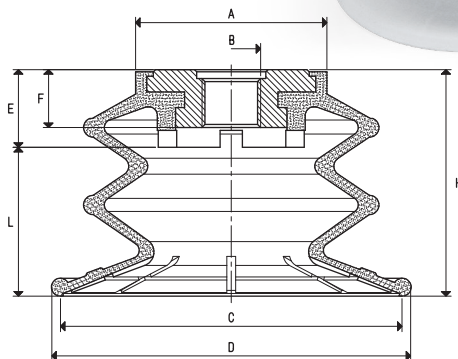

VACUUM CUPS

Item	Force Kg	Volume cm ³	A Ø	B Ø	C Ø	D Ø	E	F	H	L	Bellows stroke mm
08 75 43 SR *	11.19	74.3	43.0	G1/4"	75.5	80.5	17.5	13.7	50	32.5	28
08 110 73 SR *	24.17	250.6	63.5	G3/8"	113.4	119.0	25.5	19.4	75	49.5	40

* Complete the code indicating the compound: A= oil-resistant rubber; N= natural para rubber; S= silicone

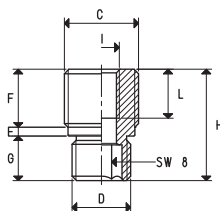

MALE SUPPORTS

Item	B	C Ø	D Ø	E	F	G	H	I	L	Support material	For vacuum cup item	Weight g
00 08 373	8	G1/4"	G1/4"	2	10	10	22	M8	11	aluminium	08 75 43 SR	4.1
00 08 372	8	G3/8"	G1/4"	2	13	10	25	M8	11	aluminium	08 75 43 SR	7.4
00 08 376	8	G3/8"	G3/8"	3	13	15.5	31.5	M8	11	aluminium	08 110 73 SR	14.1
00 08 375	8	G1/2"	G3/8"	3	13	15.5	31.5	M8	11	aluminium	08 110 73 SR	15.5

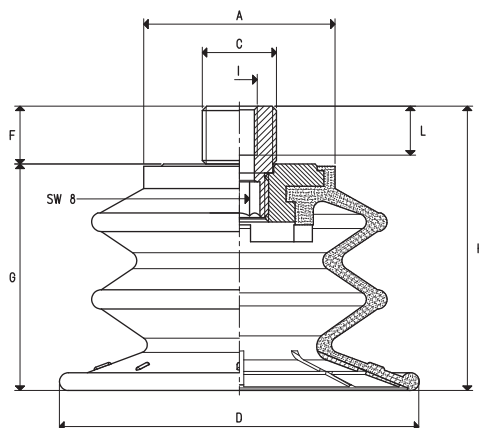

VACUUM CUPS WITH MALE SUPPORT

Item	Force Kg	A Ø	B	C Ø	D Ø	F	G	H	I	L	Vacuum cup item	Support item	Weight g
08 75 43 M *	11.19	43.0	8	G1/4"	80.5	10	50	60	M8	11	08 75 43 SR	00 08 373	75.0
08 75 43 3/8 M *	11.19	43.0	8	G3/8"	80.5	13	50	63	M8	11	08 75 43 SR	00 08 372	78.3
08 110 73 M *	24.17	63.5	8	G3/8"	119.0	13	75	88	M8	11	08 110 73 SR	00 08 376	220.3
08 110 73 1/2 M *	24.17	63.5	8	G1/2"	119.0	13	75	88	M8	11	08 110 73 SR	00 08 375	221.7

* Complete the code indicating the compound: A= oil-resistant rubber; N= natural para rubber; S= silicone

Note: The force of the vacuum cups indicated in the table represents 1/3 of the value of the theoretical force calculated at a level of vacuum of -75 KPa and a factor of safety 3.

Transformation ratio: N (newton) = Kg x 9.81 (force of gravity)

inch = $\frac{\text{mm}}{25.4}$; pounds = $\frac{\text{g}}{453.6} = \frac{\text{Kg}}{0.4536}$

Adapters for GAS - NPT threading available on page 1.130

VACUUM CUPS WITH TWO BELLOWS WITH FEMALE SUPPORTS

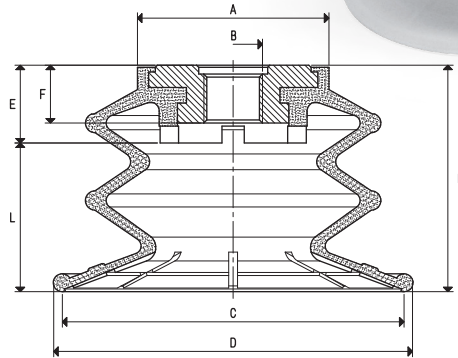
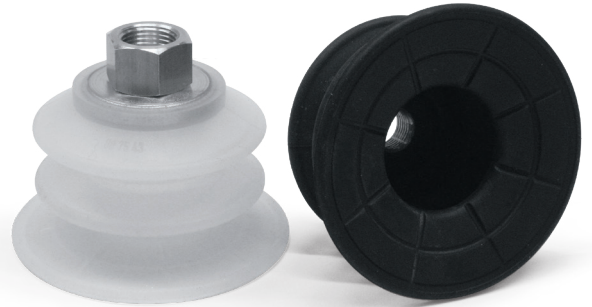

VACUUM CUPS

Item	Force Kg	Volume cm ³	A Ø	B Ø	C Ø	D Ø	E	F	H	L	Bellows stroke mm
08 75 43 SR *	11.19	74.3	43.0	G1/4"	75.5	80.5	17.5	13.7	50	32.5	28
08 110 73 SR *	24.17	250.6	63.5	G3/8"	113.4	119.0	25.5	19.4	75	49.5	40

* Complete the code indicating the compound: A= oil-resistant rubber; N= natural para rubber; S= silicone

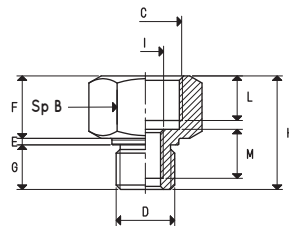

FEMALE SUPPORTS

Item	B	C Ø	D Ø	E	F	G	H	I	L	M	Support material	For vacuum cup item	Weight g
00 08 374	22	G3/8"	G1/4"	1.5	14	10.0	25.5	M8	10	11	aluminium	08 75 43 SR	12.0
00 08 377	23	G1/2"	G3/8"	3.0	17	15.5	35.5	M8	13	11	aluminium	08 110 73 SR	17.8

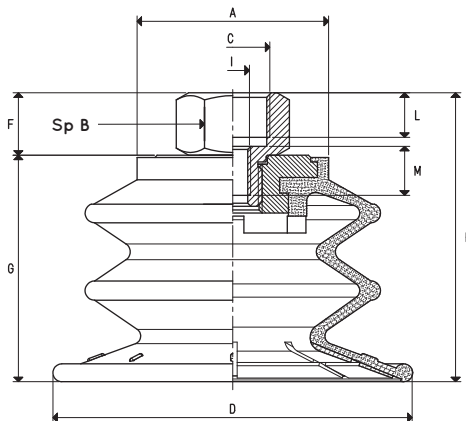

VACUUM CUPS WITH FEMALE SUPPORT

Item	Force Kg	A Ø	B	C Ø	D Ø	F	G	H	I	L	M	Vacuum cup item	Support item	Weight g
08 75 43 3/8 *	11.19	43.0	22	G3/8"	80.5	14	50	64	M8	10	11	08 75 43 SR	00 08 374	82.9
08 110 73 1/2 *	24.17	63.5	23	G1/2"	119.0	17	75	92	M8	13	11	08 75 43 SR	00 08 377	224.0

* Complete the code indicating the compound: A= oil-resistant rubber; N= natural para rubber; S= silicone

Note: The force of the vacuum cups indicated in the table represents 1/3 of the value of the theoretical force calculated at a level of vacuum of -75 KPa and a factor of safety 3.

Transformation ratio: N (newton) = Kg x 9.81 (force of gravity)

$$\text{inch} = \frac{\text{mm}}{25.4}; \text{pounds} = \frac{\text{g}}{453.6} = \frac{\text{Kg}}{0.4536}$$

Adapters for GAS - NPT threading available on page 1.130