

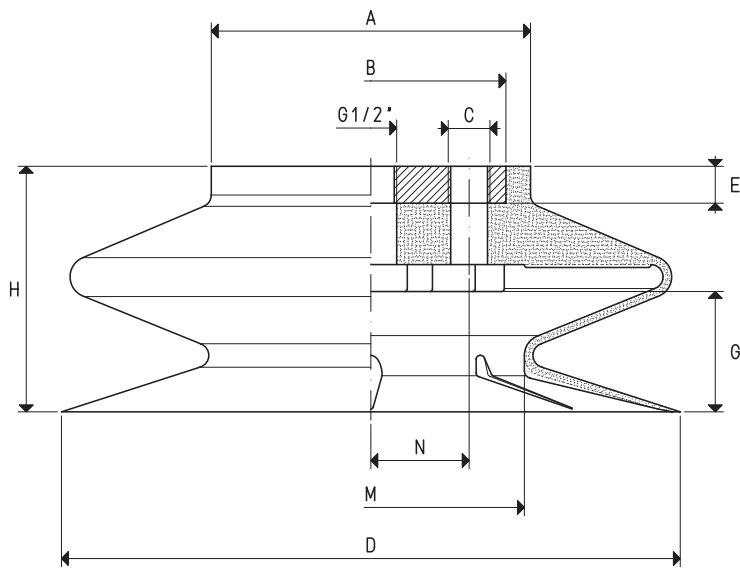

BELLOWS VACUUM CUPS WITH VULCANISED SUPPORT

The main feature of these bellows cups is that they quickly crumple up during the grip, thus lifting the load for a few centimetres, independently of the movements of the lifting frame; this quick movement avoids that the load beneath, remains stuck to the lifted one.

Due to this feature, they are particularly suited for handling thin metal sheets, glass sheets, chipboard or compressed wood panels, laminated plastic etc. Thanks to their great flexibility, they can also be used to compensate flatness errors or for gripping on inclined surfaces. These bellows cups are vulcanised onto a galvanised steel support or aluminium support and are provided with a central threaded hole for its fastening to the automatism and with a side threaded hole for vacuum connection or vacuum degree detection. This range of cups is available in the three standard compounds.



BELLOWS VACUUM CUPS WITH VULCANISED SUPPORT

Item	Force Kg	Volume cm ³	A Ø	B Ø	C Ø	D Ø	E	G	H	M Ø	N	Bellows stroke mm	Support material	Weight Kg
08 110 30 *	23.7	103.2	78	65	G1/8"	110	10	23	45	55	23	20	steel	0.35
08 150 30 *	45.0	323.3	78	65	G1/8"	150	10	33	60	75	23	31	steel	0.49
08 180 30 *	63.5	503.0	94	80	G1/8"	180	10	33	70	84	30	31	steel	0.81
08 250 30 *	122.6	1528.3	130	100	G3/8"	250	15	49	100	125	35	45	aluminium	1.54

* Complete the code indicating the compound: A= oil-resistant rubber; N= natural para rubber; S= silicone

Note: The force of the vacuum cups indicated in the table represents 1/3 of the value of the theoretical force calculated at a level of vacuum of -75 KPa and a factor of safety 3.

Transformation ratio: N (newton) = Kg x 9.81 (force of gravity)

inch = $\frac{\text{mm}}{25.4}$; pounds = $\frac{\text{g}}{453.6} = \frac{\text{Kg}}{0.4536}$

Adapters for GAS - NPT threading available on page 1.130