



SELF-LOCKING VACUUM CUPS WITH TRACTION RELEASE

These cups do not require a connection to any vacuum source, since the object onto which they are laid on evacuates the air inside them. A built-in non-return valve prevents the air from entering again, thus maintaining the vacuum.

To release the piece, simply lift it a few millimetres, thus opening the non-return valve, which restores the atmospheric pressure inside the cup, by letting the air in.

Since possible losses cannot be recovered, these cups are recommended only for holding objects with smooth and impermeable surfaces, such as glass, polished sheets, and other similar objects. They are particularly suited for glass carrying trolleys feeding trolleys for robotic systems.

They are made with nickel-plated brass with a steel drive bush, which can be provided in the anti-rotation version upon request.

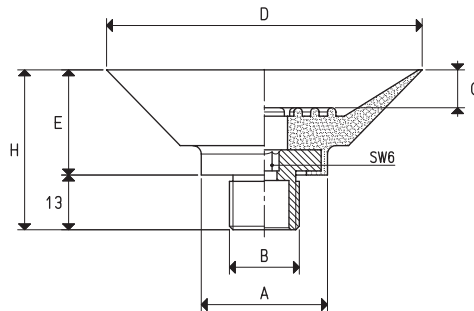

VACUUM CUPS WITH FEMALE VULCANISED SUPPORT, SPARE PART

Item	Volume cm ³	A Ø	B Ø	D Ø	E	G	H	Support material	Weight g
08 50 40 *	9.8	31	G3/8"	50	16.0	6.5	29.0	steel	38.5
08 75 40 *	27.8	31	G3/8"	75	25.0	9.0	38.0	steel	57.9
08 100 40 *	41.3	32	G3/8"	100	26.0	9.0	39.0	steel	78.3
08 100 50 *	70.3	32	G3/8"	100	30.5	15.0	43.5	steel	74.8

* Complete the code indicating the compound: B= BENZ rubber; N= natural para rubber; S = silicone

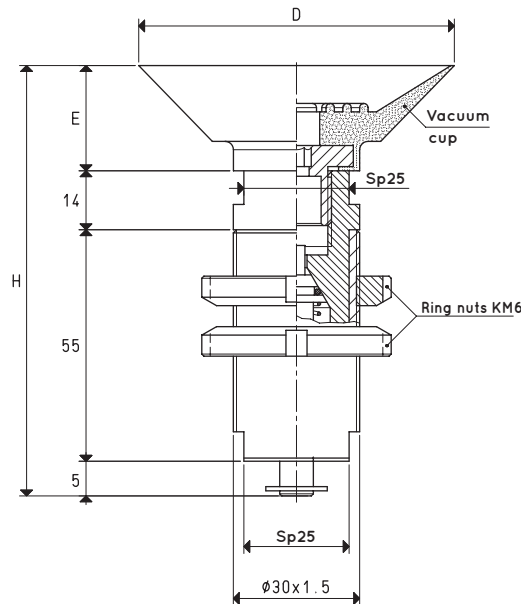

SELF-LOCKING VACUUM CUPS WITH TRACTION RELEASE

Item	Force -10 kPa Kg	D Ø	E	H	Vacuum cup item	Weight g
17 50 40 *	1.90	50	16	90	08 50 40	436
17 75 40 *	4.42	75	25	99	08 75 40	458
17 100 40 *	7.85	100	26	100	08 100 40	474
17 100 50 *	7.85	100	30	104	08 100 50	473

* Complete the code indicating the compound: B= BENZ rubber; N= natural para rubber; S = silicone

Note: The suction cup force shown in the table is calculated at a hypothetical vacuum value of -10 kPa.

Transformation ratio: N (newton) = Kg x 9.81 (force of gravity)

$$\text{inch} = \frac{\text{mm}}{25.4}; \text{pounds} = \frac{\text{g}}{453.6} = \frac{\text{Kg}}{0.4536}$$



SELF-LOCKING VACUUM CUPS WITH TRACTION RELEASE

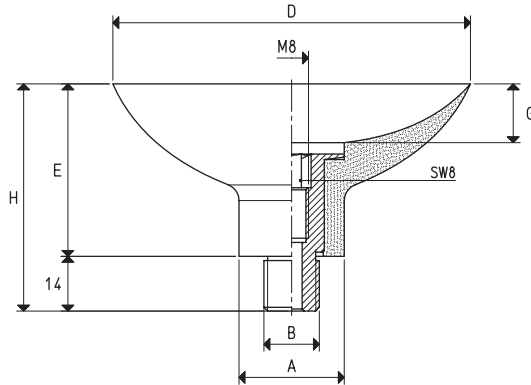

VACUUM CUPS WITH SUPPORT, SPARE PART

Item	Volume cm ³	A Ø	B Ø	D Ø	E	G	H	Vacuum cup item	Support item	Support material	Weight g
08 60 10 *	16.1	15	G1/4"	60	22	9.5	36	01 60 10	00 08 22	aluminium	20.8
08 85 10 *	48.8	25	G1/4"	85	41	14.0	55	01 85 10	00 08 28	aluminium	49.3

* Complete the code indicating the compound: A= oil-resistant rubber; N= natural para rubber; S= silicone

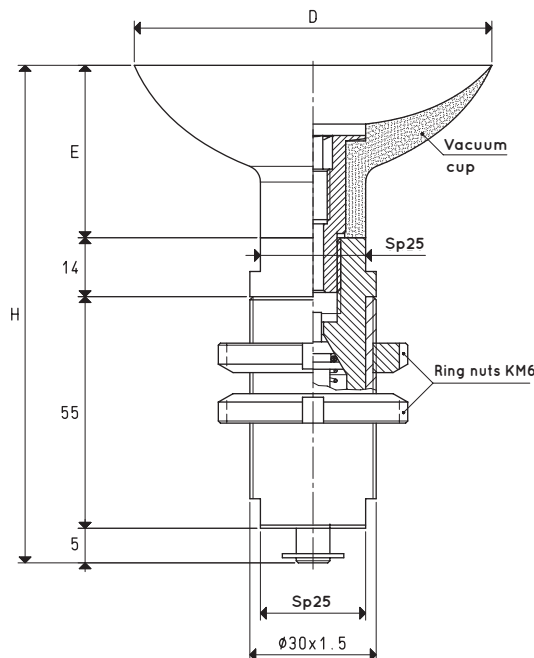

SELF-LOCKING VACUUM CUPS WITH TRACTION RELEASE

Item	Force -10 kPa Kg	D Ø	E	H	Vacuum cup item	Weight g
17 60 10 *	2.9	60	22	96	08 60 10	415
17 85 10 *	5.7	85	41	115	08 85 10	444

* Complete the code indicating the compound: A= oil-resistant rubber; N= natural para rubber; S= silicone

Note: The suction cup force shown in the table is calculated at a hypothetical vacuum value of -10 kPa.

Transformation ratio: N (newton) = Kg x 9.81 (force of gravity) inch = $\frac{\text{mm}}{25.4}$; pounds = $\frac{\text{g}}{453.6} = \frac{\text{Kg}}{0.4536}$