



SPECIAL BUILT-IN VACUUM CUPS WITH BALL VALVE

Their main feature is that they open suction and therefore they produce a vacuum, only when the load to be handled activates the sealing ball.

Especially designed for the vacuum operated beds of woodworking machines, they differ from the previously described ones because of the high precision of their cylindrical support, which is ground to size, and because of their square closing block, which prevents the cup from rotating and enables connection to vacuum.

The cold fitted cups are the flat ones listed in the table, in the various compounds.

The support of these cups is made of anodised aluminium, while the closing block is made of brass.

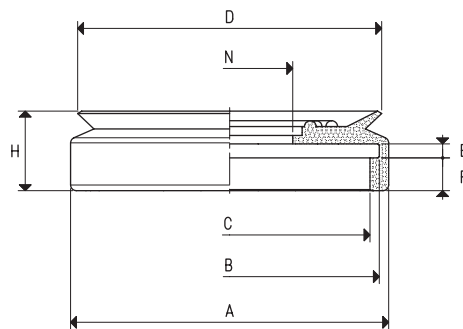

SPARE VACUUM CUP

Item	Force Kg	Volume cm ³	A Ø	B Ø	C Ø	D Ø	E	F	H	N Ø	Weight g
01 65 15 *	8.29	9.1	68	63	59	65	3	7	17	27	21.4

* Complete the code indicating the compound: A= oil-resistant rubber; N= natural para rubber; S= silicone

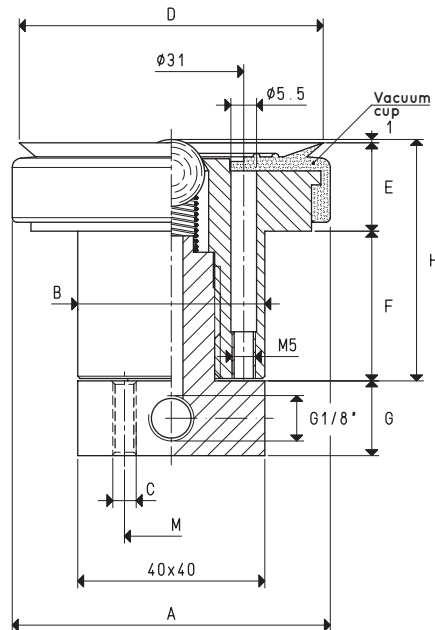

SPECIAL BUILT-IN VACUUM CUP WITH BALL VALVE

Item	Force Kg	A Ø	B Ø	C Ø	D Ø	E	F	G	H	M	Vacuum cup item	Weight g
05 65 15 M *	8.29	69	40	M5	65	19	31.5	16.0	51.5	20	01 65 15	456

* Complete the code indicating the compound: A= oil-resistant rubber; N= natural para rubber; S= silicone

Note: The force of the vacuum cups indicated in the table represents 1/3 of the value of the theoretical force calculated at a level of vacuum of -75 KPa and a factor of safety 3.

Transformation ratio: N (newton) = Kg x 9.81 (force of gravity) inch = $\frac{\text{mm}}{25.4}$; pounds = $\frac{\text{g}}{453.6} = \frac{\text{Kg}}{0.4536}$

SPECIAL BUILT-IN VACUUM CUPS WITH BALL VALVE

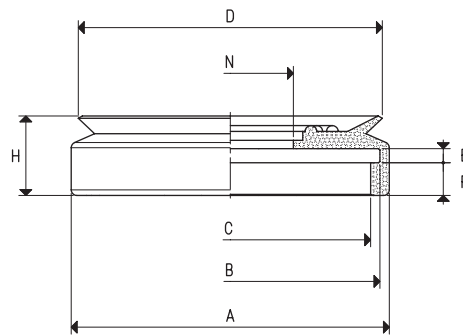

SPARE VACUUM CUP

Item	Force Kg	Volume cm ³	A Ø	B Ø	C Ø	D Ø	E	F	H	N Ø	Weight g
01 65 15 *	8.29	9.1	68	63	59	65	3	7	17	27	21.4

* Complete the code indicating the compound: A= oil-resistant rubber; N= natural para rubber; S= silicone

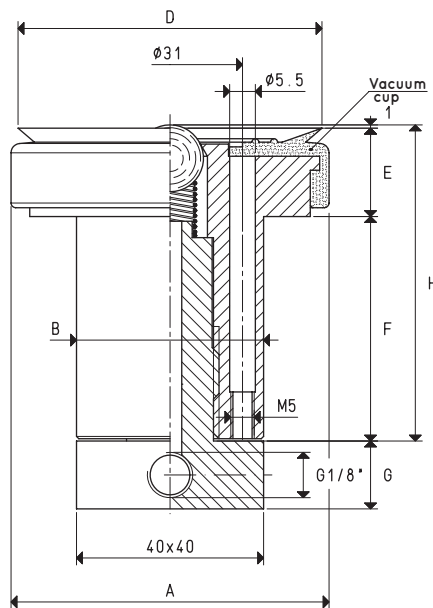

SPECIAL BUILT-IN VACUUM CUP WITH BALL VALVE

Item	Force Kg	A Ø	B Ø	D Ø	E	F	G	H	Vacuum cup item	Weight g
05 65 65 *	8.29	69	40	65	19	47.5	14.5	67.5	01 65 15	528

* Complete the code indicating the compound: A= oil-resistant rubber; N= natural para rubber; S= silicone

Note: The force of the vacuum cups indicated in the table represents 1/3 of the value of the theoretical force calculated at a level of vacuum of -75 KPa and a factor of safety 3.

Transformation ratio: N (newton) = Kg x 9.81 (force of gravity) inch = $\frac{\text{mm}}{25.4}$; pounds = $\frac{\text{g}}{453.6} = \frac{\text{Kg}}{0.4536}$



SPECIAL BUILT-IN VACUUM CUPS WITH BALL VALVE

3D drawings are available on vuotecnica.net

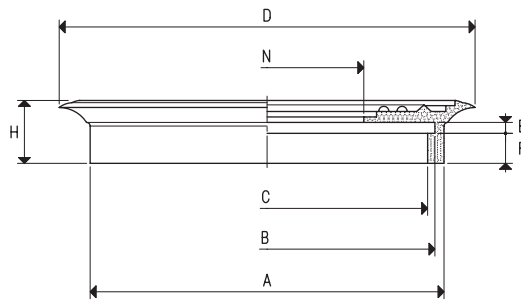
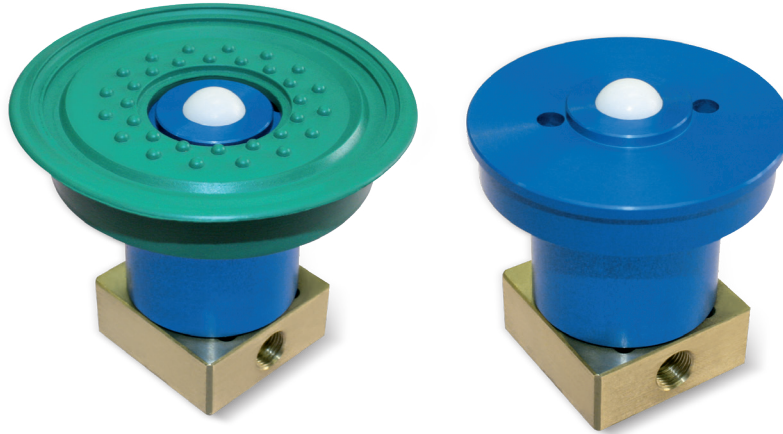

SPARE VACUUM CUPS

Item	Force Kg	Volume cm ³	A Ø	B Ø	C Ø	D Ø	E	F	H	N Ø	Weight g
01 85 15 *	14.18	13.0	68	63	59	85	3	7	17	27	29.7
01 110 10 *	23.74	24.9	96	91	87	114	3	8	17	54	44.3

* Complete the code indicating the compound: A= oil-resistant rubber; N= natural para rubber; S= silicone

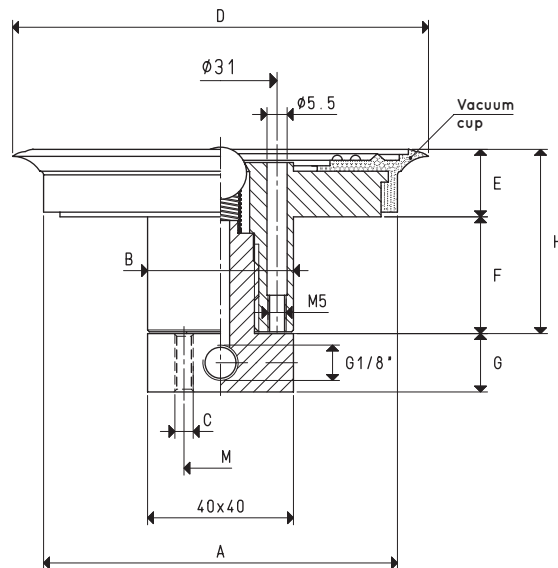

SPECIAL BUILT-IN VACUUM CUPS WITH BALL VALVE

Item	Force Kg	A Ø	B Ø	C Ø	D Ø	E	F	G	H	M	Vacuum cup item	Weight g
05 85 15 M *	14.18	69	40	M5	85	19	31.5	16.0	51.5	20	01 85 15	466
05 110 10 M *	23.74	97	40	M5	114	19	32.0	16.0	52.0	20	01 110 10	614

* Complete the code indicating the compound: A= oil-resistant rubber; N= natural para rubber; S= silicone

Note: The force of the vacuum cups indicated in the table represents 1/3 of the value of the theoretical force calculated at a level of vacuum of -75 KPa and a factor of safety 3.

Transformation ratio: N (newton) = Kg x 9.81 (force of gravity) inch = $\frac{\text{mm}}{25.4}$; pounds = $\frac{\text{g}}{453.6} = \frac{\text{Kg}}{0.4536}$

SPECIAL BUILT-IN VACUUM CUPS WITH BALL VALVE

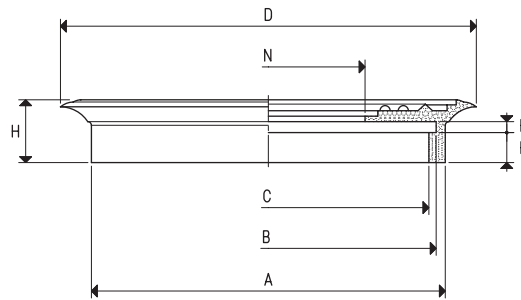
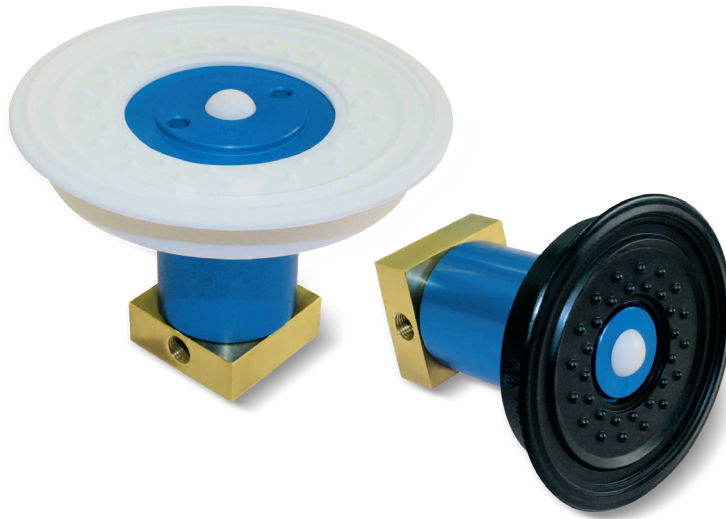

SPARE VACUUM CUPS

Item	Force Kg	Volume cm ³	A Ø	B Ø	C Ø	D Ø	E	F	H	N Ø	Weight g
01 85 15 *	14.18	13.0	68	63	59	85	3	7	17	27	29.7
01 110 10 *	23.74	24.9	96	91	87	114	3	8	17	54	44.3

* Complete the code indicating the compound: A= oil-resistant rubber; N= natural para rubber; S= silicone

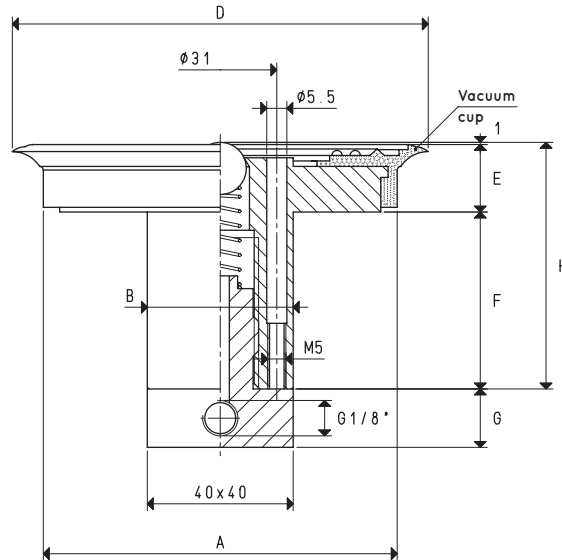

SPECIAL BUILT-IN VACUUM CUPS WITH BALL VALVE

Item	Force Kg	A Ø	B Ø	D Ø	E	F	G	H	Vacuum cup item	Weight g
05 85 65 *	14.18	69	40	85	19	47.5	14.5	67.5	01 85 15	536
05 110 65 *	23.74	97	40	114	19	48.0	14.5	68.0	01 110 10	674

* Complete the code indicating the compound: A= oil-resistant rubber; N= natural para rubber; S= silicone

Note: The force of the vacuum cups indicated in the table represents 1/3 of the value of the theoretical force calculated at a level of vacuum of -75 KPa and a factor of safety 3.

Transformation ratio: N (newton) = Kg x 9.81 (force of gravity) inch = $\frac{\text{mm}}{25.4}$; pounds = $\frac{\text{g}}{453.6} = \frac{\text{Kg}}{0.4536}$