

ROUND VACUUM CUPS WITH BALL VALVE AND SELF-LOCKING SUPPORT

These cups represent a true mobile clamping system. They are composed of:

- A sturdy anodised aluminium support with a wide surface at the base limited by a seal whose purpose is to fix it to the bearing surface.
- A standard circular flat cup which is cold fitted onto the upper part of the support for gripping the load.
- A ball valve that opens up creating vacuum, only when activated by the load to be gripped.
- Two quick couplings for vacuum connection.

The detection of vacuum, for gripping and releasing the support, can be made via three-way vacuum valves or solenoid valves.

All cups with self-locking support of this and other ranges with the gripping plane at the same height can be used simultaneously, even if they are of different types or have different sizes.

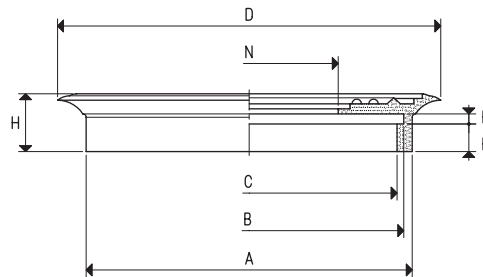

SPARE VACUUM CUPS

Item	Force Kg	Volume cm ³	A Ø	B Ø	C Ø	D Ø	E	F	H	N Ø	Weight g
01 85 15 *	14.18	13.0	68	63	59	85	3	7	17	27	29.7
01 110 10 *	23.74	24.9	96	91	87	114	3	8	17	54	44.3
01 150 10 *	45.00	75.7	133	125	118	154	4	11	23	64	112.0

* Complete the code indicating the compound: A= oil-resistant rubber; N= natural para rubber; S= silicone

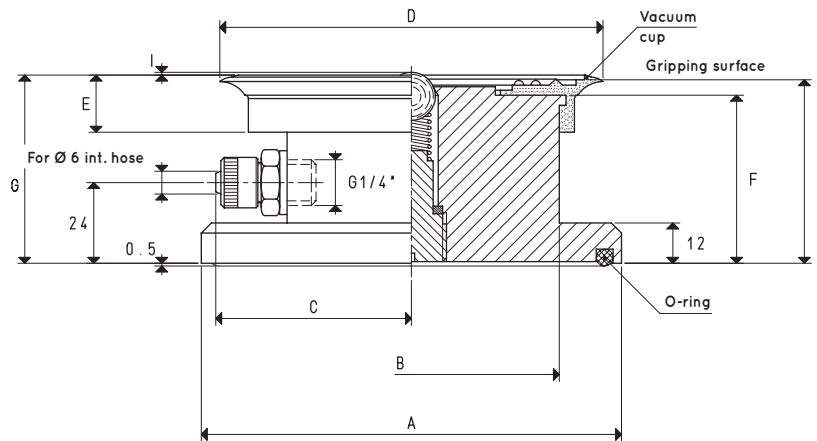

VACUUM CUPS WITH BALL VALVE AND SELF-LOCKING SUPPORT

Item	Force Kg	A Ø	B Ø	C	D Ø	E	F	G	H	I	Vacuum cup item	O-ring item	Weight Kg
18 85 15 *	14.5	98	60	41	85	17	49.0	56.0	54.5	1	01 85 15	00 16 06	0.580
18 110 10 *	24.0	125	88	58	114	17	50.0	56.0	54.5	1	01 110 10	00 16 07	1.106
18 150 10 *	45.0	165	120	76	154	23	49.5	57.5	54.5	1	01 150 10	00 16 08	1.926

* Complete the code indicating the compound: A= oil-resistant rubber; N= natural para rubber; S= silicone

Note: The force of the vacuum cups indicated in the table represents 1/3 of the value of the theoretical force calculated at a level of vacuum of -75 KPa and a factor of safety 3.

Transformation ratio: N (newton) = Kg x 9.81 (force of gravity) inch = $\frac{\text{mm}}{25.4}$; pounds = $\frac{\text{g}}{453.6} = \frac{\text{Kg}}{0.4536}$