



# RECTANGULAR VACUUM CUPS WITH BALL VALVE AND SELF-LOCKING SUPPORT

These cups represent a true mobile clamping system. They are composed of:

- A sturdy anodised aluminium support with a wide surface at the base limited by a seal whose purpose is to fix it to the bearing surface.
- A standard rectangular flat cup which is cold fitted onto the upper part of the support for gripping the load.
- A ball valve that opens up creating vacuum, only when activated by the load to be gripped.
- Two quick couplings for vacuum connection.

The detection of vacuum, for gripping and releasing the support, can be made via three-way vacuum valves or solenoid valves.

All cups with self-locking support of this and other ranges with the gripping plane at the same height can be used simultaneously, even if they are of different types or have different sizes.

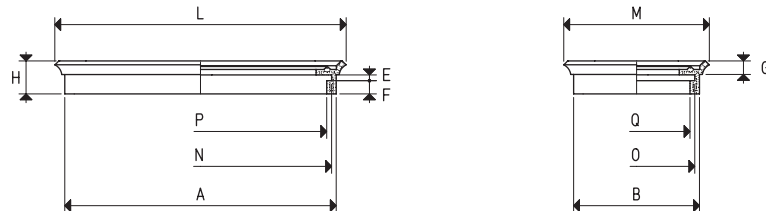

## SPARE VACUUM CUPS

Item	Force Kg	Volume cm <sup>3</sup>	A	B	E	F	G	H	L	M	N	O	P	Q	Weight g
<b>01 40 75 *</b>	6.7	9.2	64	29	3	7.5	6.5	16.0	75	40	59	24	54	19	15.6
<b>01 120 90 *</b>	24.0	42.9	107	78	3	7.5	7.5	17.5	117	87	102	73	97	68	38.8
<b>01 150 75 *</b>	25.0	43.5	137	62	3	7.5	7.5	16.5	147	72	132	57	127	52	41.2

\* Complete the code indicating the compound: A= oil-resistant rubber; N= natural para rubber; S= silicone

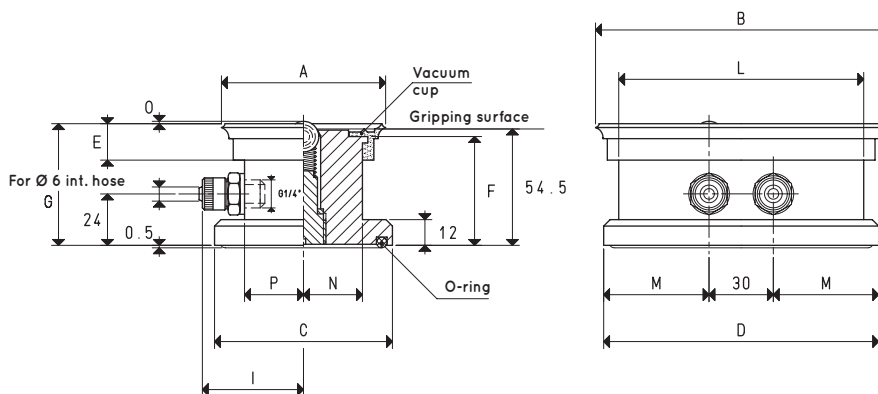

## VACUUM CUPS WITH BALL VALVE AND SELF-LOCKING SUPPORT

Item	Force Kg	A	B	C	D	E	F	G	I	L	M	N	O	P	Vacuum cup item	O-ring item	Weight Kg
<b>18 40 75 *</b>	6.7	41	76	48	83	16.0	51	56.5	41.5	55	26.5	15.0	2	21.0	01 40 75	00 05 16	0.352
<b>18 120 90 *</b>	24.0	90	120	98	128	17.5	50	57.0	56.0	102	49.0	35.0	1	35.0	01 120 90	00 16 10	1.224
<b>18 150 75 *</b>	25.0	75	150	83	144	16.5	50	57.0	48.0	130	57.0	27.5	1	27.5	01 150 75	00 16 10	1.194

\* Complete the code indicating the compound: A= oil-resistant rubber; N= natural para rubber; S= silicone

Note: The force of the vacuum cups indicated in the table represents 1/3 of the value of the theoretical force calculated at a level of vacuum of -75 KPa and a factor of safety 3.

Transformation ratio: N (newton) = Kg x 9.81 (force of gravity)      inch =  $\frac{\text{mm}}{25.4}$  ; pounds =  $\frac{\text{g}}{453.6} = \frac{\text{Kg}}{0.4536}$